

Linear axis for collaborative robots LIFTKIT

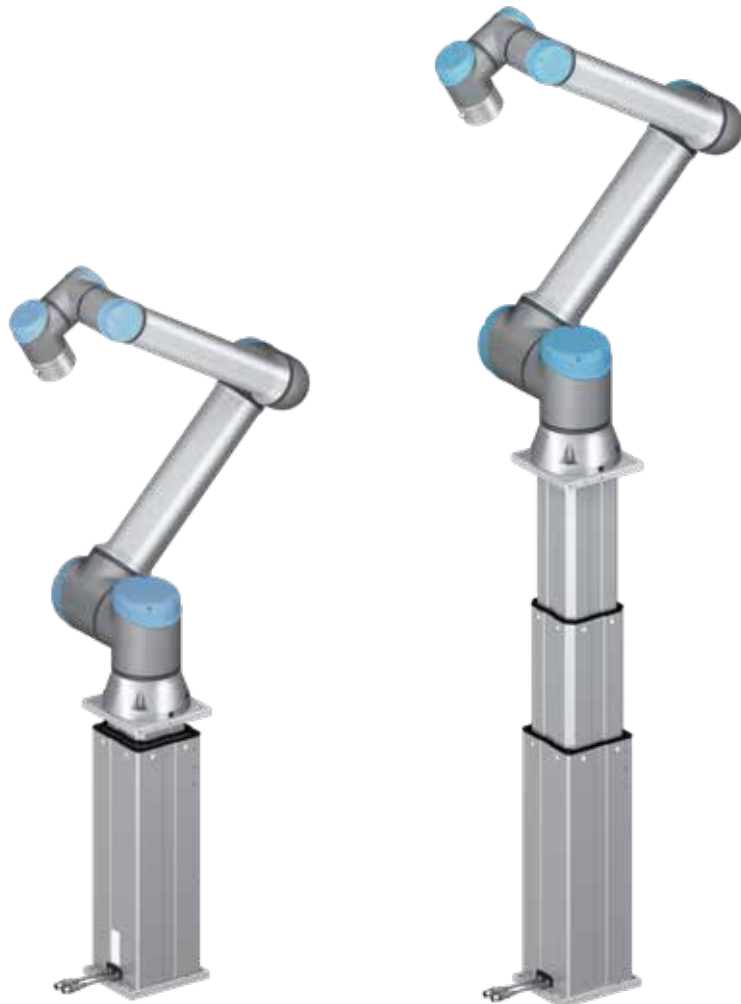

Heritage of innovation for technology leadership

Ewellix is a global innovator and manufacturer of linear motion and actuation solutions. Today, our state-of-the-art linear solutions are designed to increase machine performance, maximise uptime, reduce maintenance, improve safety and save energy.

Technology leadership

Our journey began **over 50 years** ago as part of the SKF Group, and our history with SKF provided us with the **expertise to continuously develop new technologies** and use them to create cutting edge products that offer our customers a competitive advantage.

In 2019, we became independent from SKF and changed our name to Ewellix. **We are proud of our heritage.** This gives us a unique foundation on which to build an agile business with engineering excellence and innovation as our core strengths.

Global presence and local support

With our **global presence**, we are uniquely positioned to deliver **standard components and custom-engineered solutions**, with full technical and applications support around the world. The long lasting relationships with our distributor partners allow us to support customers in a variety of different industries. At Ewellix, we don't just provide products; **we engineer integrated solutions** that help customers realise their ambitions.



1 400 employees



16 sales units



9 factories

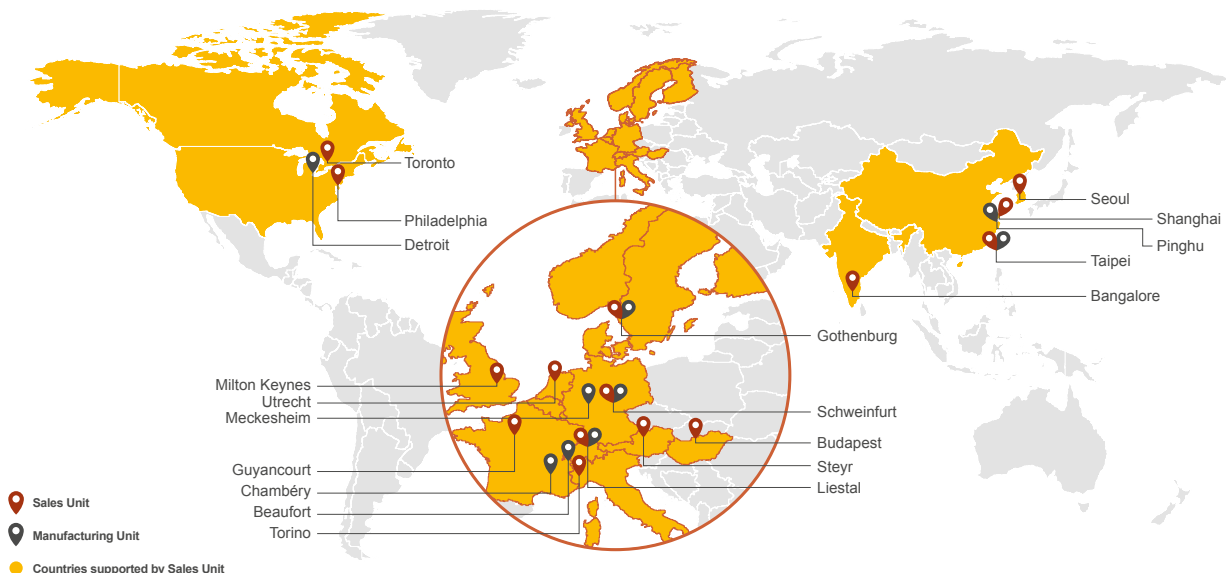

Benefits for handling

Fully automated pick and place solutions are becoming a new standard with packaging stations.

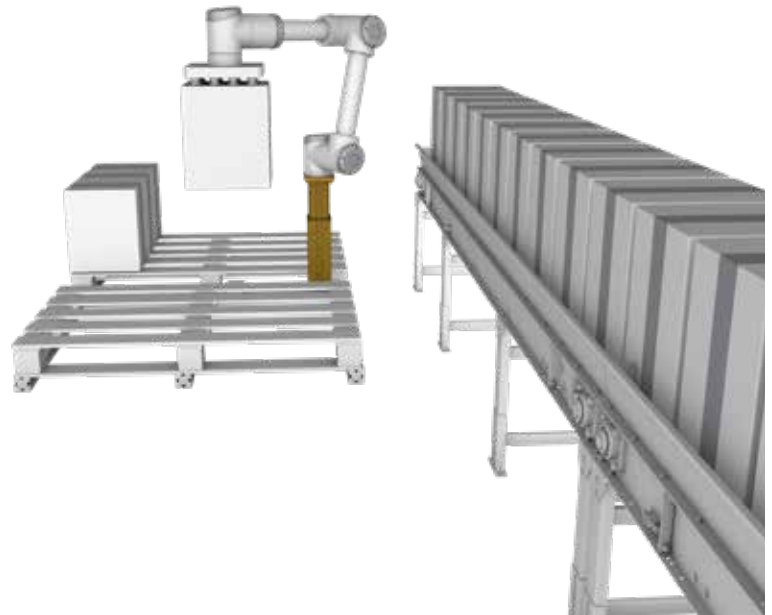

The main challenge for packaging system manufacturers is to design multi-axis systems in a simple and cost effective way.

A typical application that benefits from an added linear axis is palletizing of boxes. Stacking on pallets can start at floor level, but the stack can be up to 2 m high. A standard collaborative robot does not have such a large vertical working range.

Ewellix provides effective solutions to complete vertical adjustment in a smart way, providing a ready to mount additional linear axis to the robot. While stacking a pallet, the base of the robot can be lifted or lowered to work at a more optimal position.

LIFTKIT

Operating range extension

- Vertical lifting of the cobot by up to 900 mm with compact retracted height
- Robust pillar design for industrial use, vibration free motion and virtually maintenance free

Plug-and-play solution

- Hardware interface compatible with UR3, UR5 and UR10 robots
- Universal Robots+ certified product
- Software control integrated with UR controller (URCaps) for easy motion programming

Cost savings and higher productivity

- UR cobots combined with SKF Motion Technologies LIFTKIT provide a cost-effective solution to upgrade an existing assembly shop, moving from a manual handled to a fully automatized line.



Technical data

	Unit	LIFTKIT-UR-601
Mechanical		
Push load	N	1 500 N
Pull load	N	0 N
Speed	mm/s	80 mm/s
Stroke	mm	500 – 900 mm
Retracted length (hardware)	mm	Stroke/2 + 265 mm
Retracted length (software controlled)	mm	Stroke/2 + 275 mm
Height of attachment plates	mm	2x15 mm
Cross section	mm	163 mm x 163 mm
Type of protection	IP	40
Ambient temperature	°C	+10 to +40 °C
Compatibility to UR	-	UR3, UR5, UR10, e-Series
Cable management	-	Threads on pillar and interface plate to attach cable management
Electrical		
Voltage/Current	V/A	120 AC / 6.5 230 AC / 3,3 24 DC / 10
Emergency stop	-	Connection to UR safety IO
Software functionality		
Positioning, repeatability	mm	± 1 mm
Accessible positions	-	any
Feedback	-	Position feedback via URCaps
Soft start and stop	-	Implemented for smooth operation
Universal Robots controller compatibility		CB 3.1 / Polyscope 3.6 or higher

Dimensional drawing

TLT telescopic pillar

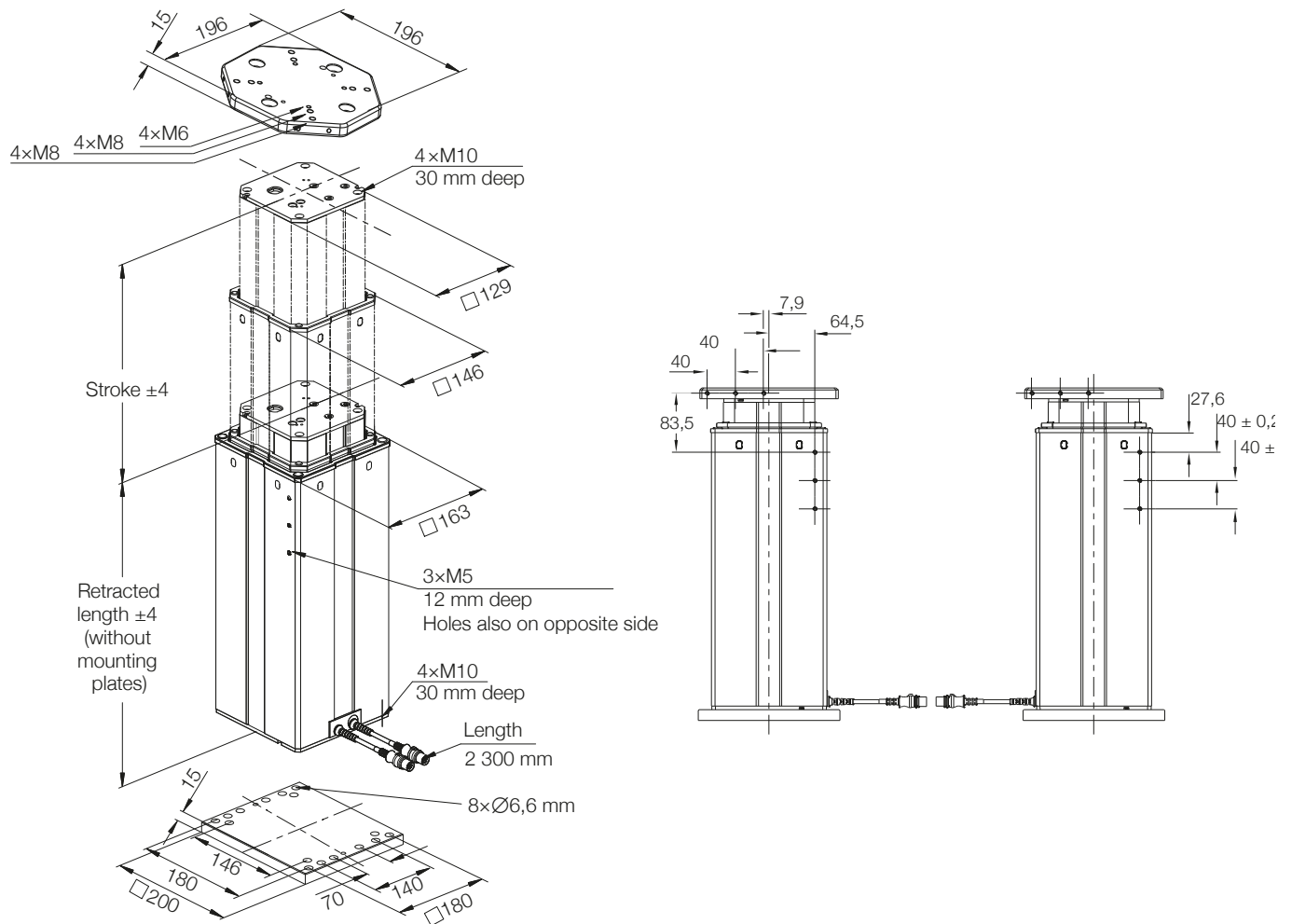

Control unit

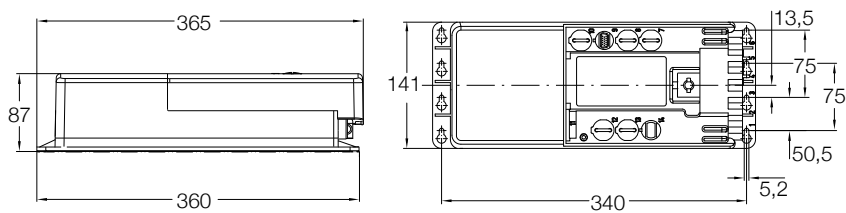

Connection diagram

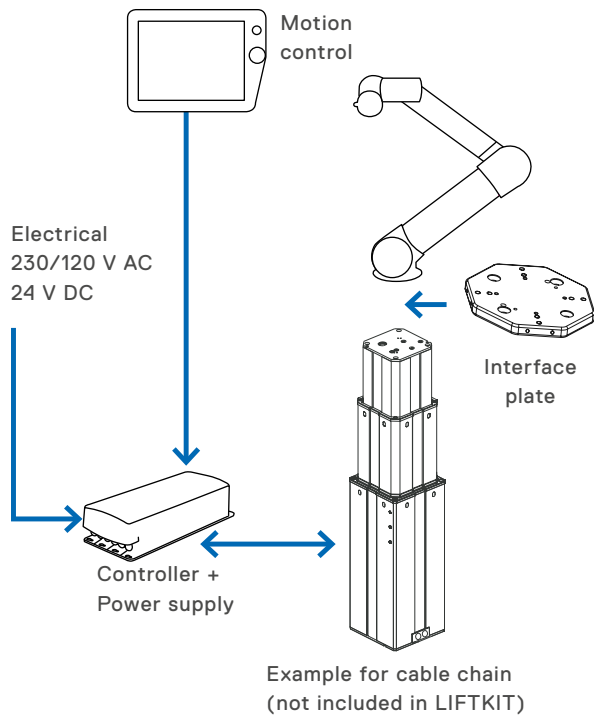

Cable management

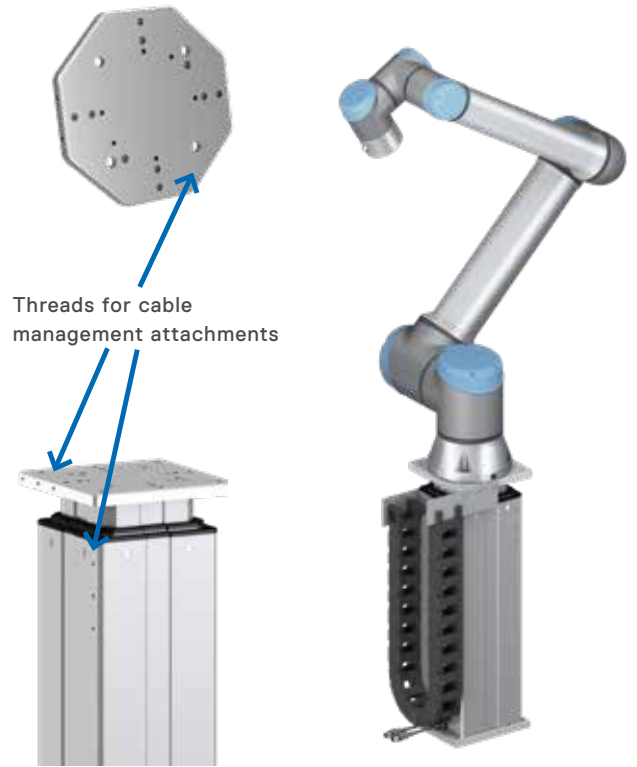

LIFTKIT contains



Software functionality

The URcaps software for the LIFTKIT allows easy positioning access directly within the UR Polyscope environment.

Setup

In the installation tab, the user can manually move the linear axis in both directions and define multiple user specific positions, that are accessible in programming mode.

Motion programming

Within the UR motion program, the LIFTKIT axis is easily integrated through a URcaps command module. Simply insert this element from the structure tab at the desired position of the program. Additionally, reading and setting positions is possible through a script function.

Safety elements

The LIFTKIT has a range of safety elements built in to allow its integration into a robot application.

NOTE:

The LIFTKIT is not a functional safety system compliant with EN ISO 13489-1 or IEC 62061. To integrate the LIFTKIT into a functional safety chain, external safety devices have to be integrated into the overall system.



LIFTKIT software functionality

Ordering key



Robot
UR Universal Robots

Stroke
500 mm
600 mm
700 mm
800 mm
900 mm

Electrical options
00 24 V DC
11 120 V AC / US cable
22 230 V AC / EU cable
23 230 V AC / CN cable
24 230 V AC / UK cable
25 230 V AC / CH cable

Pillar type
601 TLT

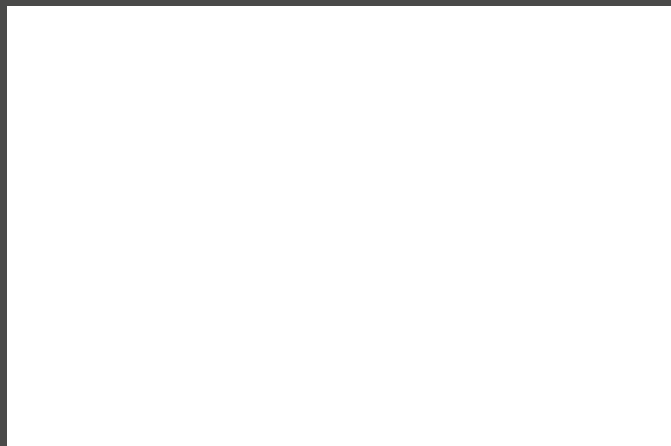

ewellix.com

© Ewellix

All contents of this publication are the property of Ewellix, and may not be reproduced or given to third parties (even extracts) without permission. Although great care has been taken in the production of this catalog, Ewellix does not take any responsibility for damage or other loss resulting from omissions or typographical errors. The photo may differ slightly in appearance from the actual product. Due to continuous improvements being made in our products, the product's appearance and specifications are subject to change without notice.

PUB EL-07022-EN-October 2019

Certain image(s) used under license from Shutterstock.com.
SKF and SKF logo are trademarks of the SKF Group