

# Linear actuator CAHB series





# CAHB series

Designed to operate in harsh environment with temperatures from  $-40$  to  $85$  °C up to 25 % duty cycle, Ewellix electromechanical actuator CAHB family features robust metal gears and corrosion-resistant housings.

Available in 7 series - CAHB-20A/20E/21E/22E for medium and heavy load applications with an over load protection by clutch, CAHB-10, a compact solution for low-load applications and CAHB-30A/31N for AC version- Ewellix electromechanical actuators, are virtually maintenance-free, self-locking up to 2 times the rated load and rated up to IP69K/66M. Additional design options are available like limit switches, positioning feedback and manual override.



## Features

- Long stroke and high speed
- High holding force up to 20 000 N
- Absolute or incremental Position feedback and limit switches option
- Low backlash
- Manual override option
- Overload and thermal protection
- Ingress protection IP69K/66M with vent
- Stainless steel push tube and Corrosion protected metal parts
- Wide temperature range ( $-40$  to  $85$  °C)
- Mechanical, electrical and climatic tests
- High efficiency
- Virtually maintenance-free

See **pages 38 and 39** for test results.

## Benefits

- High productivity and usability of the adjustment
- Reliability and safety
- Save development time and shorten the time to market
- Cost effectiveness
- Durable

# CAHB-10

## Linear actuator

### Benefits

- Compact design
- Designed for harsh environment
- Robust and reliable
- Integrated limit switches
- Quiet operation
- Thermal protection
- Optional potentiometer and 2-Hall encoder available
- Electromagnetic compatibility (EMC) compliant



### Technical data

Designation	Unit	CAHB-10... 1	CAHB-10... 2	CAHB-10... 3	CAHB-10... 4	CAHB-10... 5	CAHB-10... 6
Push load	N	120	240	500	750	1 000	1 500
Pull load	N	120	240	500	750	1 000	1 500
Speed (full load to no load)	mm/s	45 to 56	24 to 30	13 to 16	8 to 10	6 to 8	5 to 8
Stroke	mm	50 to 300	50 to 300	50 to 300	50 to 300	50 to 300	50 to 300
Retracted length	mm	- <sup>1)</sup>	- <sup>1)</sup>	- <sup>1)</sup>	- <sup>1)</sup>	- <sup>1)</sup>	- <sup>1)</sup>
Voltage	V DC	12 or 24	12 or 24	12 or 24	12 or 24	12 or 24	12 or 24
Power consumption	W	N/A	N/A	N/A	N/A	N/A	N/A
Current consumption 12 V DC	A	4	3,5	3,2	3	2,8	4,4
24V DC	A	2,2	2	1,8	1,8	1,6	2,8
Duty cycle	%	25	25	25	25	25	20
Ambient temperature	°C	-40 to +85	-40 to +85	-40 to +85	-40 to +85	-40 to +85	-40 to +85
Type of protection	IP	66s/69k	66s/69k	66s/69k	66s/69k	66s/69k	66s/69k
Weight (at 300 mm stroke)	kg	1,5	1,5	1,5	1,5	1,5	1,5
Color	-	Silver	Silver	Silver	Silver	Silver	Silver
Limit switches	-	Yes	Yes	Yes	Yes	Yes	Yes
Thermal protection	-	Yes	Yes	Yes	Yes	Yes	Yes

<sup>1)</sup> For basic configuration see dimensional drawing (L→ page 5)

For potentiometer configuration see dimensional drawing (L→ page 6)



## Dimensional drawing

### Basic configuration and optional 2-Hall encoder

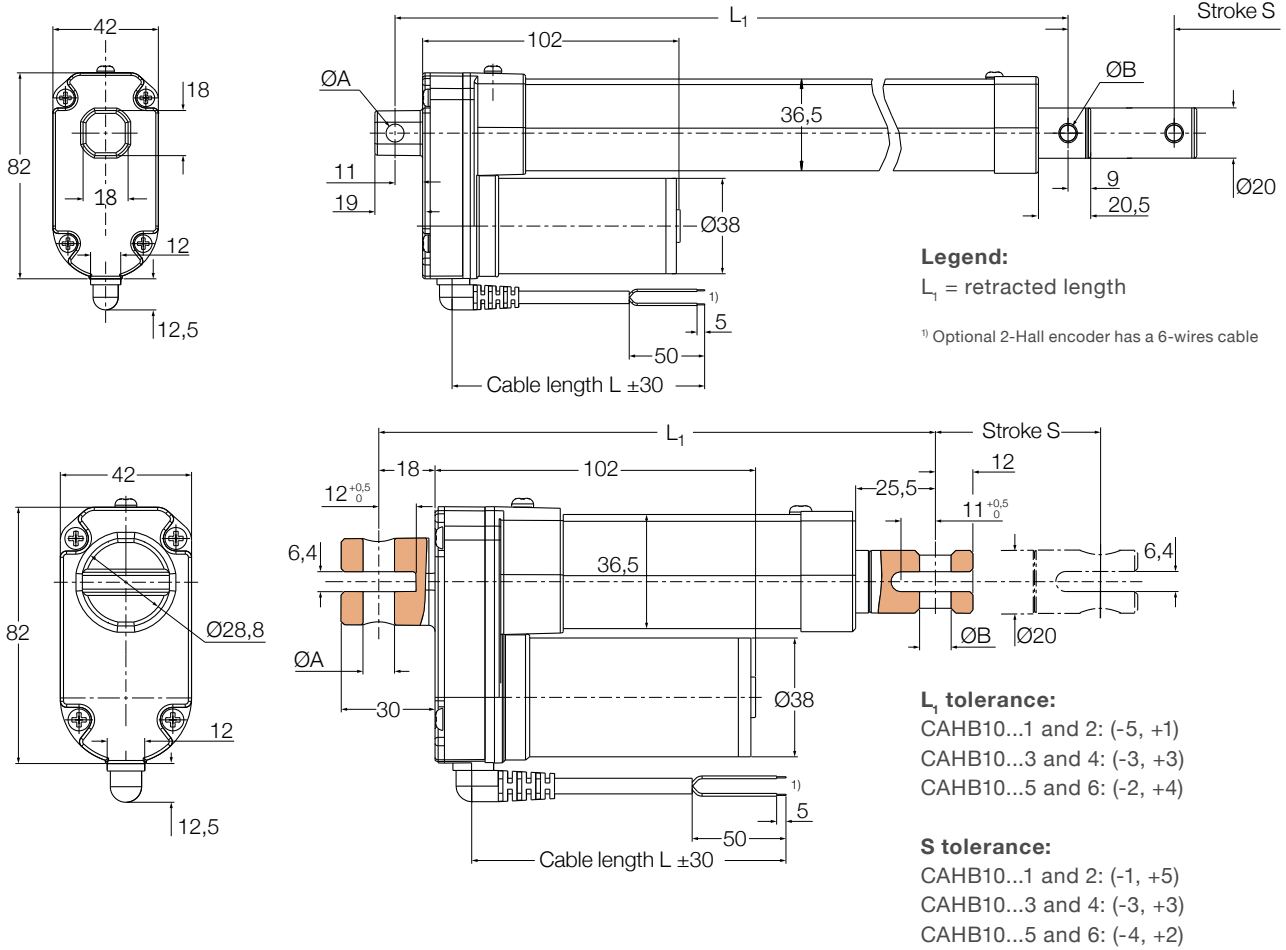

Stroke [mm]	50	100	150	200	250	300
Retracted length ( $L_1$ )	158	209	260	311	362	413
Retracted length with fork head	179	230	281	332	383	434

## Performance diagrams

### Speed-load diagram

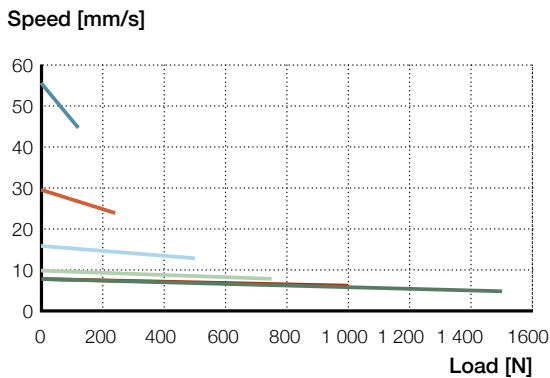

### Current-load diagram

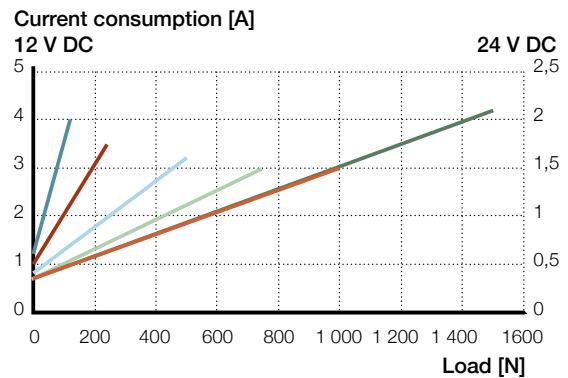

- CAHB-10...1
- CAHB-10...3
- CAHB-10...5
- CAHB-10...4
- CAHB-10...6

Dimensional drawing

Optional potentiometer

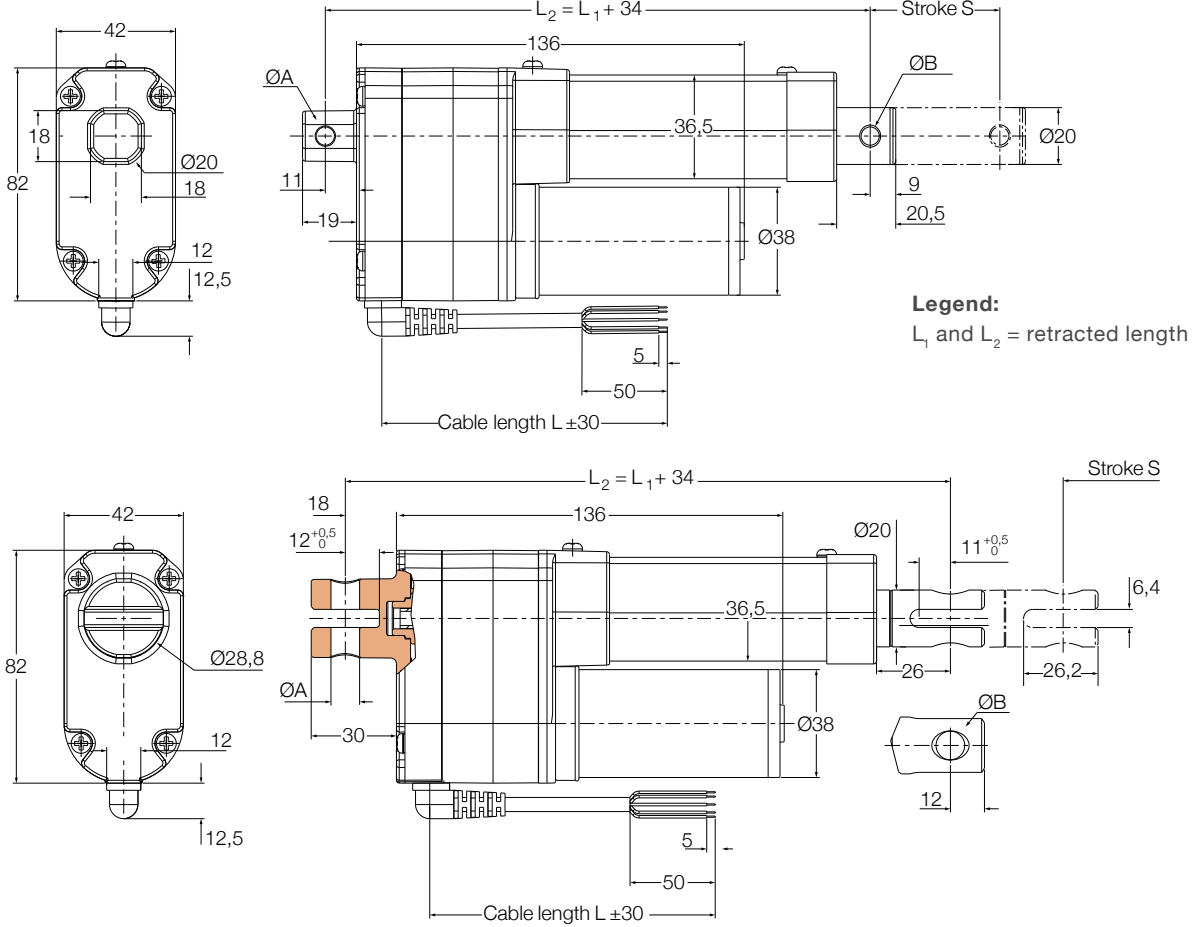

**$L_1$  tolerance:**  
 CAHB10...1 and 2: (-5, +1)  
 CAHB10...3 and 4: (-3, +3)  
 CAHB10...5 and 6: (-2, +4)

**S tolerance:**  
 CAHB10...1 and 2: (-1, +5)  
 CAHB10...3 and 4: (-3, +3)  
 CAHB10...5 and 6: (-4, +2)

Stroke (mm)	50	100	150	200	250	300
Retracted length ( $L_2$ )	192	243	294	345	396	447
Retracted length with fork head	213	264	315	366	417	468

Attachment

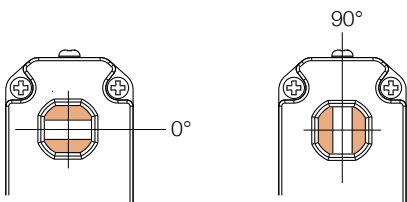

## Encoder resolution

Type	CAHB-10...1	CAHB-10...2	CAHB-10...3	v CAHB-10...4	CAHB-10...5/6
mm/pulse	0,3	0,15	0,075	0,05	0,0375

## Potentiometer resolution

Stroke [mm]	50~80	80~160	160~300
Minimum resistance value of potentiometer	700~1 300 Ω	700~1 300 Ω	700~1 300 Ω
Potentiometer resolution	100 Ω/mm	50 Ω/mm	16,6 Ω/mm

## Absolute analog output

Stroke [mm]	50~80	80~160	160~300
Initial value VS RL position (V)	0,5	0,5	0,5
Resolution (mm)	0,024	0,049	0,146
Position feedback change (V/mm)	0,05	0,025	0,0083

## Connecting diagram

### Basic configuration 12/24 V DC

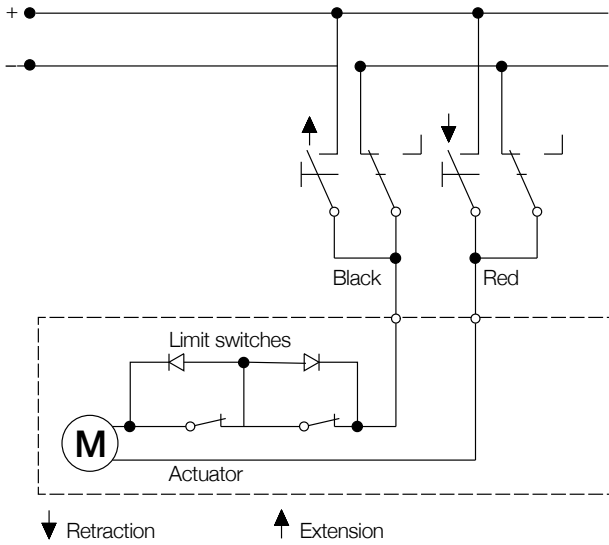

### 2-Hall encoder 12/24 V DC

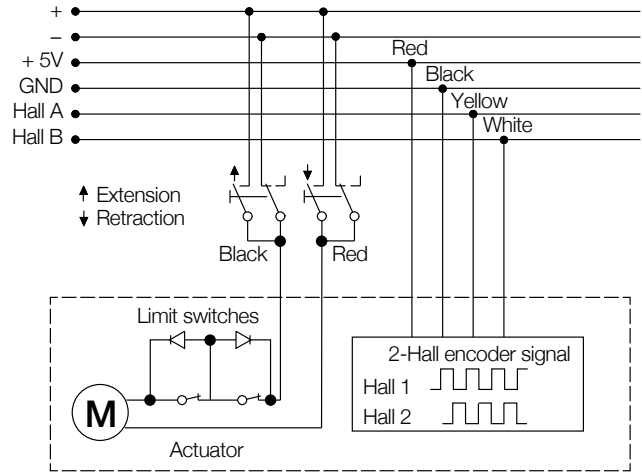

### Potentiometer

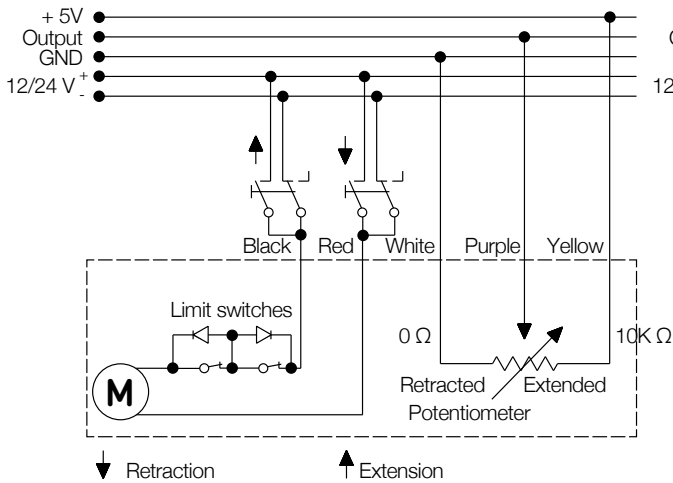

### Absolute analog output

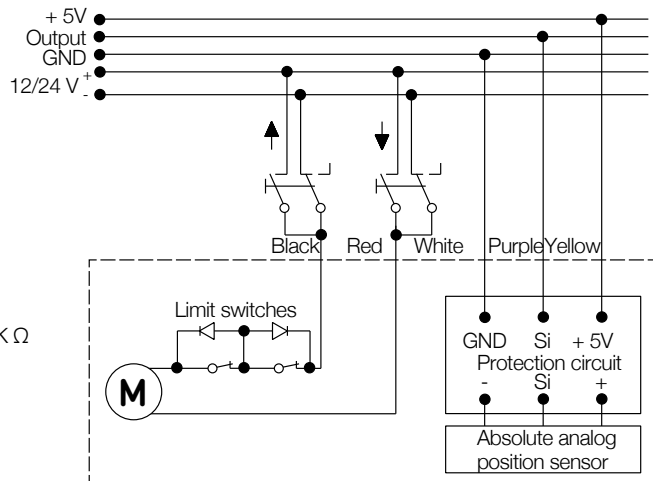





# CAHB-20A

## Linear actuator

### Benefits

- ACME screw drive
- Extension tube (stainless steel)
- Protection tube (steel)
- Enhanced corrosion resistance
- Mechanical overload protection (clutch)
- Lubricated for service life
- Robust, designed for tough environment
- Self-locking
- Certified (CE: EN 55011)



### Technical data

Designation	Unit	CAHB-20... 1	CAHB-20... 2
<b>Performance data</b>			
Push load	N	1 500	2 500
Pull load	N	1 500	2 500
Speed (full load to no load)	mm/s	27 to 33	13 to 17
Stroke	mm	102 to 610	102 to 610
Retracted length mm <sup>-1)</sup> <sub>-1)</sub>	mm	- <sup>1)</sup>	- <sup>1)</sup>
Voltage	V DC	12 or 24	12 or 24
Power consumption	W	N/A	N/A
Current consumption 12 V DC	A	16	14
24 V DC	A	8	7
Duty cycle	%	25	25
Ambient temperature	°C	-40 to +85	-40 to +85
Type of protection	IP	66	66
Weight (at 305 mm stroke)	kg	5,5	5,5
Color	-	Black	Black

<sup>1)</sup> See dimensional drawing (↳ page 11 and 12)

## Dimensional drawing

### Basic configuration (dashed line for optional limit switch)

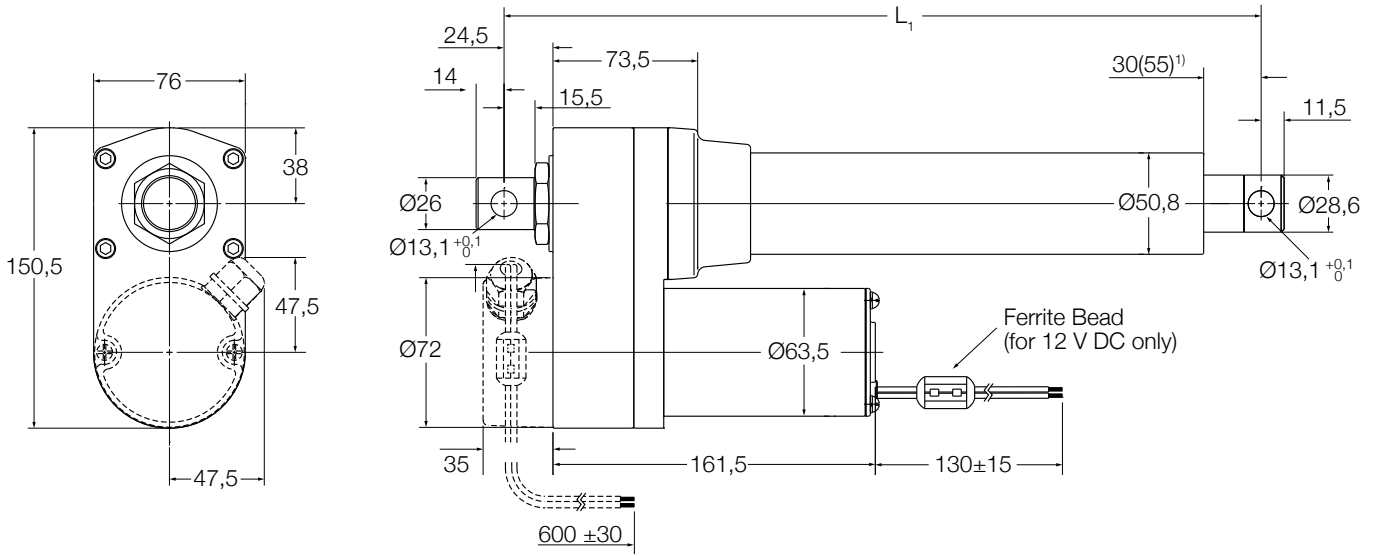

**Without limit switch:**

RED (+) & BLACK (-) = retraction  
 RED (-) & BLACK (+) = extension

**With limit switch:**

RED (+) & BLACK (-) = extension  
 RED (-) & BLACK (+) = retraction

**Legend:**

$L_1$  = retracted length  
 1)55 = dimension with limit switch

	With limit switch <sup>1)</sup>						Without limit switch <sup>2)</sup>					
Stroke [mm]	102	153	204	305	457	610	102	153	204	305	457	610
$L_1$ Retracted length	338	389	440	592	744	897	262	313	364	465	668	821

<sup>1)</sup> Tolerance: S and  $L_1 = \pm 5,0$  mm (if  $S \geq 305$  mm,  $S = \pm 7,5$  mm)

<sup>2)</sup> Tolerance:  $S = \pm 2,5$  mm and  $L = \pm 3,8$  mm

## Performance diagrams

### Speed-load diagram

Speed [mm/s]

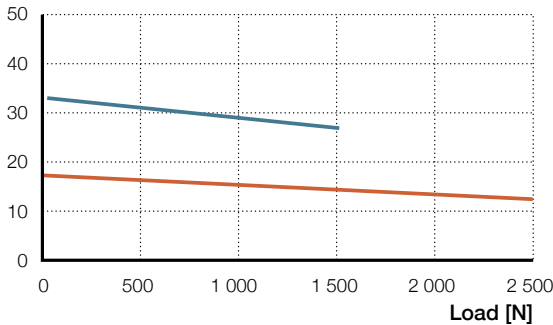

### Current-load diagram

Current consumption [A]

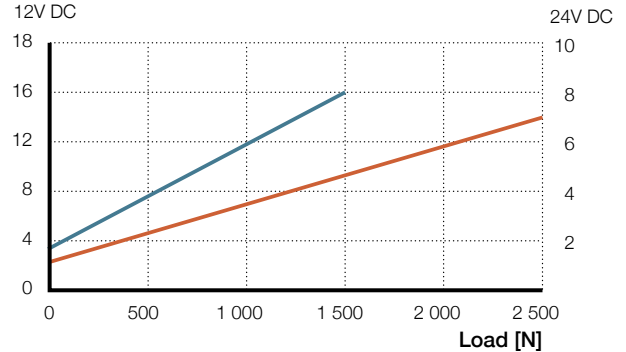

— CAHB-20...1      — CAHB-20...2

## Dimensional drawing

Optional potentiometer (dashed line for optional limit switch)

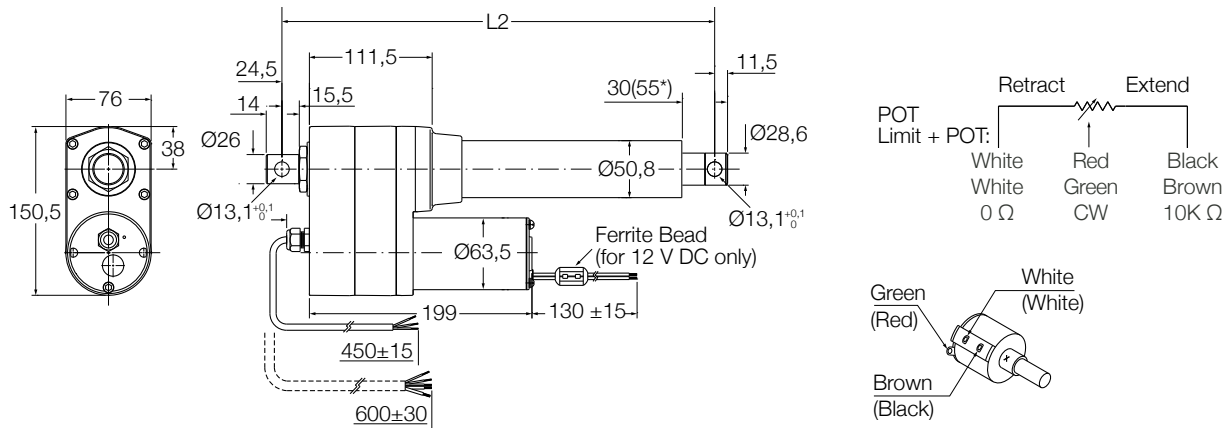

**Without limit switch:**  
 RED (+) & BLACK (-) = retraction  
 RED (-) & BLACK (+) = extension

**With limit switch:**  
 RED (+) & BLACK (-) = extension  
 RED (-) & BLACK (+) = retraction

**Legend:**  
 L2 = retracted length  
<sup>1</sup>55 = dimension with limit switch

	With limit switch <sup>1)</sup>						Without limit switch <sup>2)</sup>					
Stroke [mm]	102	153	204	305	457	610	102	153	204	305	457	610
L <sub>1</sub> Retracted length	376	427	478	630	782	935	300	351	402	503	706	859

<sup>1)</sup> Tolerance: S and L1 = ± 5,0 mm (If S ≥ 305 mm, S = ± 7,5 mm)

<sup>2)</sup> Tolerance: S = ± 2,5 mm and L2 = ± 3,8 mm

## Potentiometer resolution

Stroke [mm]	102	153	204	305	457	610
Ohm/mm	59,0	59,0	29,5	29,5	9,84	9,84

## Connecting diagram

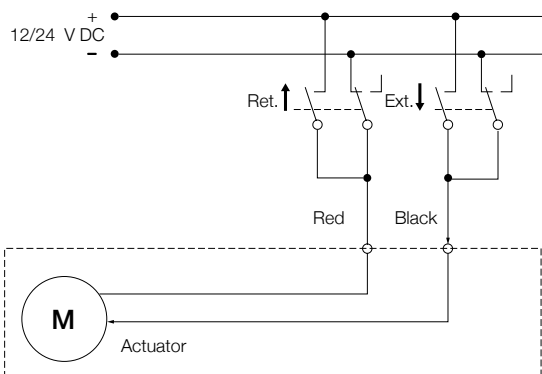

## Different rear attachment

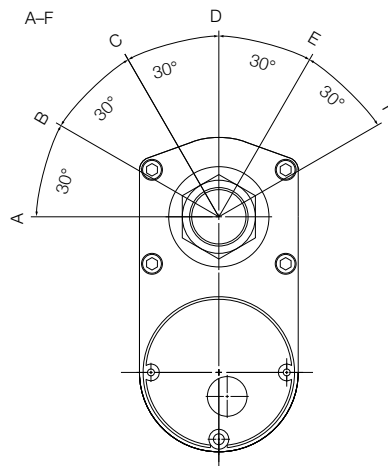

## Ordering key

C
A
H
B
-
2
0
-
 
A
-
 
 
 
 
 
-
A
 
 
 
 
 
 
-
0
0
0

**Type** \_\_\_\_\_

**Voltage** \_\_\_\_\_

A 12 V DC  
B 24 V DC

**Load** \_\_\_\_\_

1 1 500 N  
2 2 500 N

**Design** \_\_\_\_\_

**Stroke** \_\_\_\_\_

102 102 mm  
153 153 mm  
204 204 mm  
305 305 mm  
457 457 mm  
610 610 mm

**Retracted length** \_\_\_\_\_

Stroke	with limit switch	without POT	with POT
102 mm		338	376
153 mm		389	427
204 mm		440	478
305 mm		592	630
457 mm		744	782
610 mm		897	935
	without limit switch		
102 mm		262	300
153 mm		313	351
204 mm		364	402
305 mm		465	503
457 mm		668	706
610 mm		821	859

**Ingress protection** \_\_\_\_\_

A Standard: IP66

**Front attachment** \_\_\_\_\_

A Standard (Standard (hole: Ø13,1 mm))  
X Customized

**Rear attachment** \_\_\_\_\_

A Standard (0° and hole: Ø13,1 mm)  
B 30°  
C 60°  
D 90°  
E 120°  
F 150°  
X Customized

**Option 1** \_\_\_\_\_

0 None  
L Limit switch (only for load version 2 500 N)

**Option 2** \_\_\_\_\_

0 None  
P Potentiometer

**Option 3** \_\_\_\_\_

0 None  
T Thermal protection

**Customization** \_\_\_\_\_

In standard, the actuators are IP69K / IP66M and equipped with GORE Automotive vent, built-in thermal protection, protection Clutch and EMC filter.

# CAHB-20E

## Linear actuator

### Benefits

- High productivity
- Reliability and safety
- Save development time
- Cost effectiveness

### Features

- Holding force
- Mechanical overload protection
- Enhanced ingress protection
- Corrosion protection and stainless steel tube
- Manual override option
- Virtuality maintenance free



### Technical data

Designation	Unit	CAHB-20E / 12 V			CAHB-20E / 24 V		
<b>Performance data</b>							
Rated Push Force	N	1 500	2 500	4 500	1 500	2 500	4 500
Rated Pull Force	N	1 500	2 500	4 500	1 500	2 500	4 500
Max pull / push Force <sup>1)</sup>	N	2 600	3 800	6 300	2 600	3 800	6 300
Holding force <sup>2)</sup>	N						
Speed without load <sup>3)</sup>	mm/s	27,0	23,5	13,5	29,0	22,0	13,0
Speed with the rated force <sup>3)</sup>	mm/s	24,5	17,5	10,5	25,5	19,0	11,0
<b>Electric data</b>							
Nominal voltage	V DC	12	12	12	24	24	24
Nominal current @ rated load <sup>3)</sup>	A	12,5	15	17	5	6,5	8
Rated current (clutch activation)	A	18,4	21	22,4	6,8	8,8	10,4
Duty cycle	%	10 (85/765 s)	10 (85/765 s)	10 (85/765 s)	20 (85/340 s)	20 (85/340 s)	20 (85/340 s)
<b>Mechanical data</b>							
Stroke	mm	50 ... 700	50 ... 700	50 ... 700	50 ... 700	50 ... 700	50 ... 700
Backlash	mm	0,6	0,6	0,6	0,6	0,6	0,6
Weight for 200 mm stroke	kg	4,5	4,5	4,5	4,5	4,5	4,5
Colour	–	Black	Black	Black	Black	Black	Black
<b>Environment and standards</b>							
Ambient temperature <sup>4)</sup>	°C	–40 ... 85	–40 ... 85	–40 ... 85	–40 ... 85	–40 ... 85	–40 ... 85
Degree of protection	–	IP 69K/66M					
Standards / EMC	–	EN61000-6-2:2005, EN61000-6-4:2007/A1:2011					
Salt spray test	–	ISO 9227:2012, 250 hours					

<sup>1)</sup> Upper limit of the pull/push force limited by the clutch. The lower limit is just above the rated force. The limitation of the force will happen between these 2 limits

<sup>2)</sup> Ultimate Static Load, refer to the "Static load" diagrams

<sup>3)</sup> The data of speed and current on this list is defined at +20 °C

<sup>4)</sup> Full performance from 0 °C to +40 °C



## Dimensional drawing

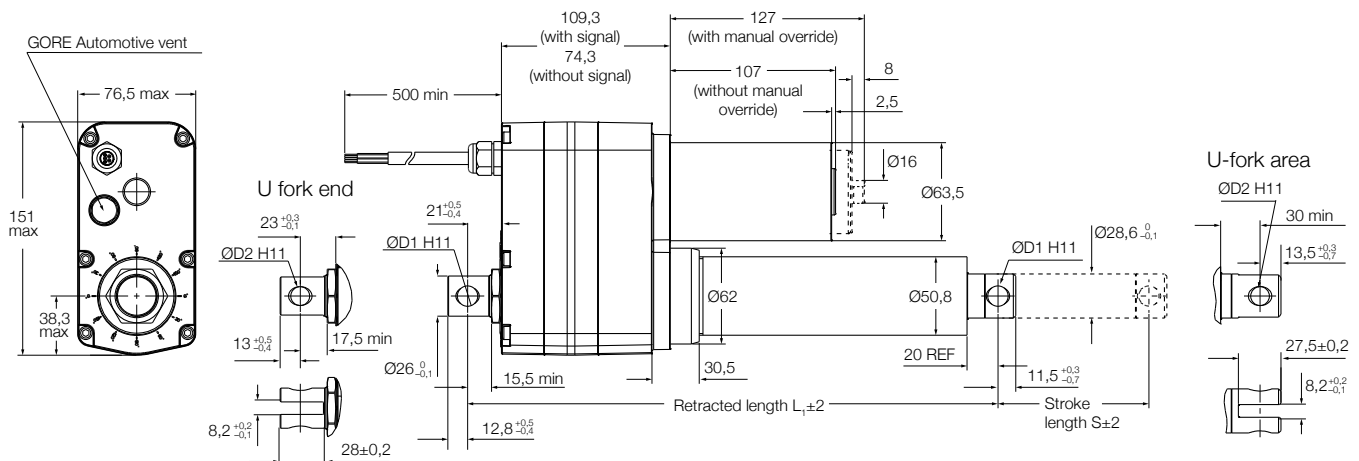

Rod end attachment (D1)

U fork attachment (D2)

Holes symbol	A	B	C	D	E	F	G
Hole dimension	13,1	12,8	12,5	14	12,2	12,2	12,8

	Rod end attachment	U fork attachment
S Stroke [mm]	50-305	306-700
L <sub>1</sub> retracted length no option	160 + stroke	211 + stroke
L <sub>1</sub> retracted length with signal	195 + stroke	246 + stroke

## Technical data

Designation	Unit	CAHB-20E / 48 V		
<b>Performance data</b>				
Rated Push Force	N	1 500	2 500	4 500
Rated Pull Force	N	1 500	2 500	4 500
Max pull / push Force <sup>1)</sup>	N	2 600	3 800	6 300
Holding force <sup>2)</sup>	N			
Speed without load <sup>3)</sup>	mm/s	31,0	23,0	13,0
Speed with the rated force <sup>3)</sup>	mm/s	27,5	20,0	11,0
<b>Electric data</b>				
Nominal voltage	V DC	48	48	48
Nominal current @ rated load <sup>3)</sup>	A	2,6	3,8	4,2
Rated current (clutch activation)	A	4,3	5,6	5,8
Duty cycle	%	20 (85/340 s)	20 (85/340 s)	20 (85/340 s)
<b>Mechanical data</b>				
Stroke	mm	50 ... 700	50 ... 700	50 ... 700
Backlash	mm	0,6	0,6	0,6
Weight for 200 mm stroke	kg	4,5	4,5	4,5
Colour	-	Black	Black	Black
<b>Environment and standards</b>				
Ambient temperature <sup>4)</sup>	°C	-40 ... 85	-40 ... 85	-40 ... 85
Degree of protection	-	IP 69K/66M		
Standards / EMC	-	EN61000-6-2:2005, EN61000-6-4:2007/A1:2001		
Salt spray test	-	ISO 9227:2012, 250 hours		

<sup>1)</sup> Upper limit of the pull/push force limited by the clutch. The lower limit is just above the rated force. The limitation of the force will happen between these 2 limits

<sup>2)</sup> Ultimate Static Load, refer to the "Static load" diagrams

<sup>3)</sup> The data of speed and current on this list is defined at +20 °C

<sup>4)</sup> Full performance from 0 °C to +40 °C

### Performance diagrams

Speed-load diagram

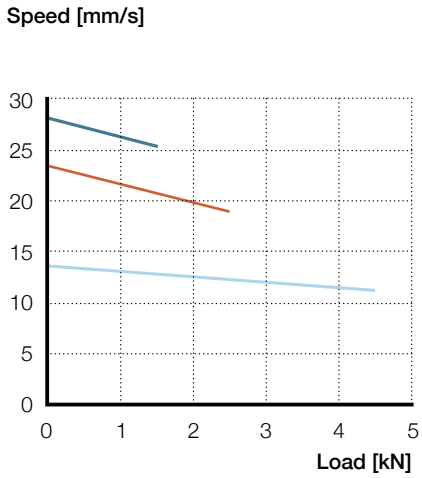

- Rated push force 1 500
- Rated push force 2 500
- Rated push force 4 500

Current load diagram

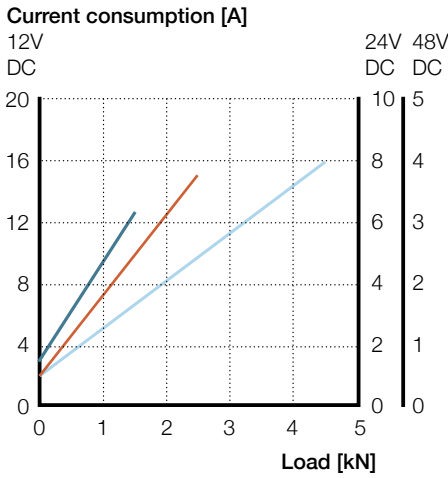

Static load diagram

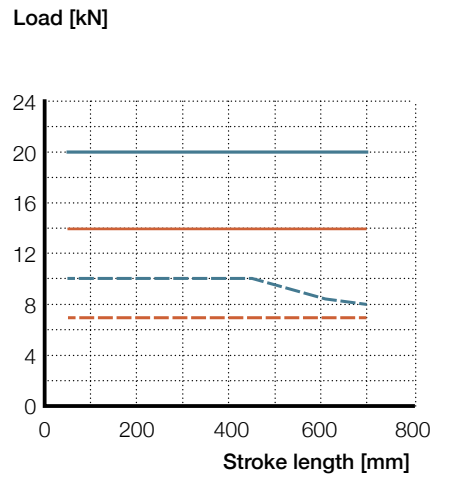

- Ultimate CAHB-20-xxE (pull)
- - - Ultimate CAHB-20-xxE (push)
- Recommended CAHB 20-xxE (pull)
- - - Recommended CAHB 20-xxE (push)

### Manual override

Release the motor cover (1). Use the slot (2) to rotate the motor shaft (3) in the proper direction

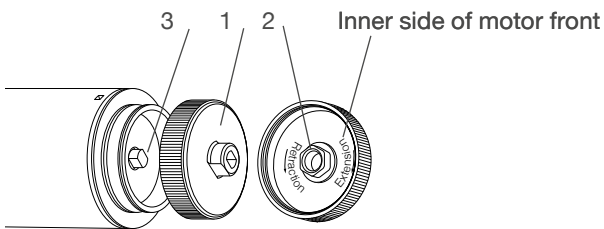

### Attachment

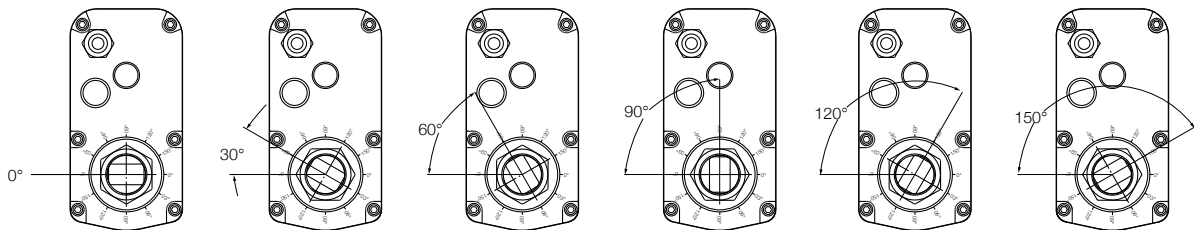

## Electrical specifications

### Wire connection with no signal

Wire no.	AWG	Colour	Application
1	14	Red	Motor power(+)=> Extension, (-)=> Retraction
2	14	Black	Motor power(-)=> Extension, (+)=> Retraction

### Wire connection with potentiometer

Wire no.	AWG	Colour	Application
1	22	Green	See picture description
2	22	White	See picture description
3	22	Brown	See picture description
4	14	Red	Motor power(+)=> Extension, (-)=> Retraction
5	14	Black	Motor power(-)=> Extension, (+)=> Retraction

### Wire connection with encoder

Wire no.	AWG	Colour	Application
1	26	Green	Sensor signal 1 Encoder
2	26	Yellow	Sensor signal 2 Encoder
3	26	Black	Sensor power GND Encoder
4	26	Red	Sensor power 5 V Encoder
5	14	Red	Motor power(+)=> Extension, (-)=> Retraction
6	14	Black	Motor power(-)=> Extension, (+)=> Retraction

### Wire connection with absolute analog output

Wire no.	AWG	Colour	Application
1	22	Green	Output signal
2	22	White	Sensor power GND
3	22	Brown	Sensor power +10~55 VDC
4	14	Red	Motor power(+)=> Extension, (-)=> Retraction
5	14	Black	Motor power(-)=> Extension, (+)=> Retraction

### Potentiometer

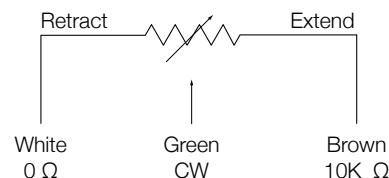

### Encoder

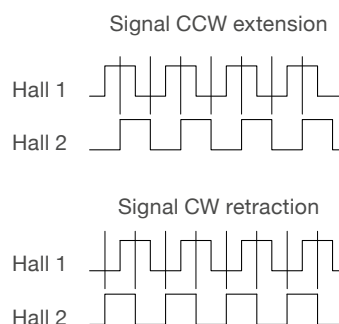

### Absolut analog position output

Input voltage: 10~55 V DC  
 Current consumption: 15 mA max.  
 Output analog signal (voltage): 0~5 V DC  
 Max current output: 5 mA  
 Absolute analog output set up:  
 retraction 0,5±0,15 V  
 extension 4,5 to the maximum

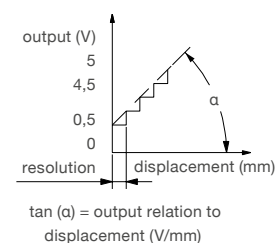

### Output relation to displacement and resolution

Actuator type	Hall sensor [pulses/mm]	Potentiometer [ohm/mm]	Absolute analogue position output [V/mm]	Resolution of the absolute analog position output [mm]
CAHB-20...E	2,76	59,06 if S=050-125	0,0295 if S=050-125	0,0413 if S=050-125
		29,53 if S=126-250	0,0148 if S=126-250	0,0827 if S=126-250
		9,84 if S=251-700	0,0049 if S=251-700	0,2480 if S=251-700

Ordering key

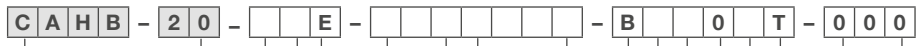

Type

Voltage

- A 12 V DC
- B 24 V DC
- D 48 V DC
- E 12 V DC with manual override
- F 24 V DC with manual override
- H 48 V DC with manual override

Load

- 1 1 500 N
- 2 2 500 N
- 3 4 500 N

Design

E

Stroke

- 100 100 mm
- 150 150 mm
- 200 200 mm
- 250 250 mm
- 300 300 mm
- 350 350 mm
- 400 400 mm
- 450 450 mm
- 500 500 mm
- 600 600 mm
- 700 700 mm

Retracted length<sup>1)</sup>

Stroke	without position output	with position output
100 mm	260	295
150 mm	310	345
200 mm	360	395
250 mm	410	445
300 mm	460	495
350 mm	561	596
400 mm	611	646
450 mm	661	696
500 mm	711	746
600 mm	811	846
700 mm	911	946

Ingress protection

B Standard: IP69K/IP66M

Attachment diameter: (Front and rear)

- A Hole Ø13,1 H11 (+0, +0,11 mm)
- B Hole Ø12,8 H11 (0, +0,11 mm)
- C Hole Ø12,5 H11 (+0, +0,11mm)
- D Hole Ø14 H11(+0,+0,11mm)
- E Hole 12.2 H11(+0,+0,11mm)
- F U fork hole 12.2 H11
- G U fork hole 12.8 H11
- X Customized

Attachment orientation

- A Standard (0°)
- B 30°
- C 60°
- D 90°
- E 120°
- F 150°
- X Customized

Option 1: Limit switch

0 Not available

Option 2: Position output

- 0 None
- A Absolute analog output
- P Potentiometer
- E Encoder

Thermal protection

T Standard: Built-in thermal switch

Customization

Stroke length, retracted length, cable, connector, front attachment, rear attachment, color, de-rated load

<sup>1)</sup> Retracted length +12mm when attachments U fork are used.

In standard, the actuators are IP69K / IP66M and equipped with GORE Automotive vent, built-in thermal protection, protection Clutch and EMC filter.

# CAHB-21E

## Linear actuator

### Benefits

- High productivity
- Reliability and safety
- Save development time
- Cost effectiveness

### Features:

- High holding force
- High speed
- Mechanical overload protection
- Enhanced ingress protection
- Corrosion protection and stainless steel tube
- Manual override option
- Virtuality maintenance free



### Technical data

Designation	Unit	CAHB-21E / 12 V			CAHB-21E / 24 V		
<b>Performance data</b>							
Rated Push Force	N	1 500	2 500	4 500	1 500	2 500	4 500
Rated Pull Force	N	1 500	2 500	4 500	1 500	2 500	4 500
Max pull / push Force <sup>1)</sup>	N	2 500	3 600	6 300	2 500	3 600	6 300
Holding force <sup>2)</sup>	N						
Speed without load <sup>3)</sup>	mm/s	49,5	37	24,0	52,5	38	22,5
Speed with the rated force <sup>3)</sup>	mm/s	43	31,5	19,0	50	31,5	21,0
<b>Electric data</b>							
Nominal voltage	V DC	12	12	12	24	24	24
Nominal current @ rated load <sup>3)</sup>	A	14,5	16	19	7	7,5	10,5
Rated current (clutch activation)	A	19,2	20,2	24,8	9,1	9,3	13,7
Duty cycle	%	10 (85/765 s)	10 (85/765 s)	10 (85/765 s)	20 (85/340 s)	20 (85/340 s)	20 (85/340 s)
<b>Mechanical data</b>							
Stroke	mm	50 ... 700	50 ... 700	50 ... 700	50 ... 700	50 ... 700	50 ... 700
Backlash	mm	0,6	0,6	0,6	0,6	0,6	0,6
Weight for 200 mm stroke	kg	4,8	4,8	4,8	4,8	4,8	4,8
Colour	–	Black	Black	Black	Black	Black	Black
<b>Environment and standards</b>							
Ambient temperature <sup>4)</sup>	°C	–40 ... 85	–40 ... 85	–40 ... 85	–40 ... 85	–40 ... 85	–40 ... 85
Degree of protection	–	IP 69K/66M					
Standards / EMC	–	EN61000-6-2:2005, EN61000-6-4:2007/A1:2011					
Salt spray test	–	ISO 9227:2012, 250 hours					

<sup>1)</sup> Upper limit of the pull/push force limited by the clutch. The lower limit is just above the rated force. The limitation of the force will happen between these 2 limits

<sup>2)</sup> Ultimate Static Load, refer to the "Static load" diagrams

<sup>3)</sup> The data of speed and current on this list is defined at +20 °C

<sup>4)</sup> Full performance from 0 °C to +40 °C

## Technical data

Designation	Unit	CAHB-21E / 48 V		
<b>Performance data</b>				
Rated Push Force	N	1 500	2 500	4 500
Rated Pull Force	N	1 500	2 500	4 500
Max pull / push Force <sup>1)</sup>	N	2 500	3 600	6 300
Holding force <sup>2)</sup>	N			
Speed without load <sup>3)</sup>	mm/s	51,5	41,0	23,5
Speed with the rated force <sup>3)</sup>	mm/s	46,0	33,5	19,0
<b>Electric data</b>				
Nominal voltage	V DC	48	48	48
Nominal current @ rated load <sup>3)</sup>	A	4,0	4,5	5,0
Rated current (clutch activation)	A	5,6	6,1	6,4
Duty cycle	%	20 (85/340 s)	20 (85/340 s)	20 (85/340 s)
<b>Mechanical data</b>				
Stroke	mm	50 ... 700	50 ... 700	50 ... 700
Backlash	mm	0,6	0,6	0,6
Weight for 200 mm stroke	kg	4,8	4,8	4,8
Colour	–	Black	Black	Black
<b>Environment and standards</b>				
Ambient temperature <sup>4)</sup>	°C	–40 ... 85	–40 ... 85	–40 ... 85
Degree of protection	–	IP 69K/66M		
Standards / EMC	–	EN61000-6-2:2005, EN61000-6-4:2007/A1:2011		
Salt spray test	–	ISO 9227:2012, 250 hours		

<sup>1)</sup> Upper limit of the pull/push force limited by the clutch. The lower limit is just above the rated force. The limitation of the force will happen between these 2 limits

<sup>2)</sup> Ultimate Static Load, refer to the "Static load" diagrams

<sup>3)</sup> The data of speed and current on this list is defined at +20 °C

<sup>4)</sup> Full performance from 0 °C to +40 °C

## Performance diagrams

Speed-load diagram

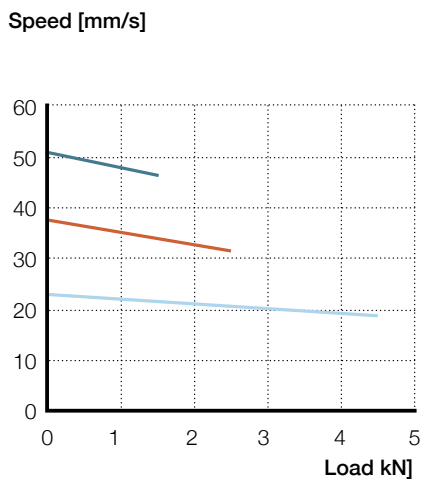

- Rated push force 1 500
- Rated push force 2 500
- Rated push force 4 500

Current load diagram

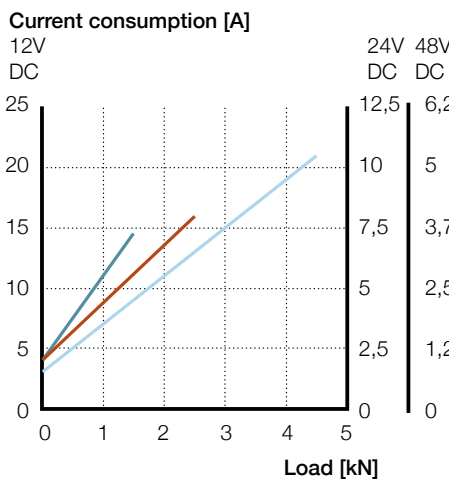

Static load diagram

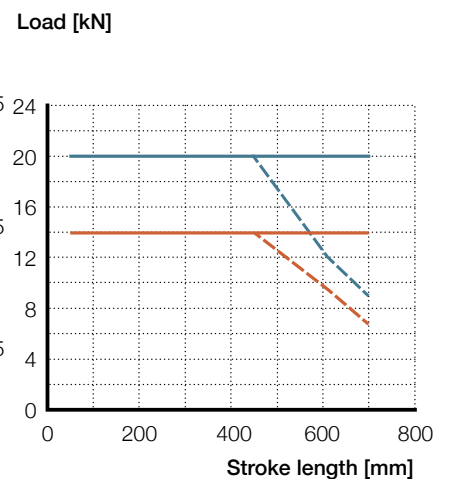

- Ultimate CAHB-21-xxE (pull)
- - - Ultimate CAHB-21-xxE (push)
- Recommended CAHB 21-xxE (pull)
- - - Recommended CAHB 21-xxE (push)



### Dimensional drawing

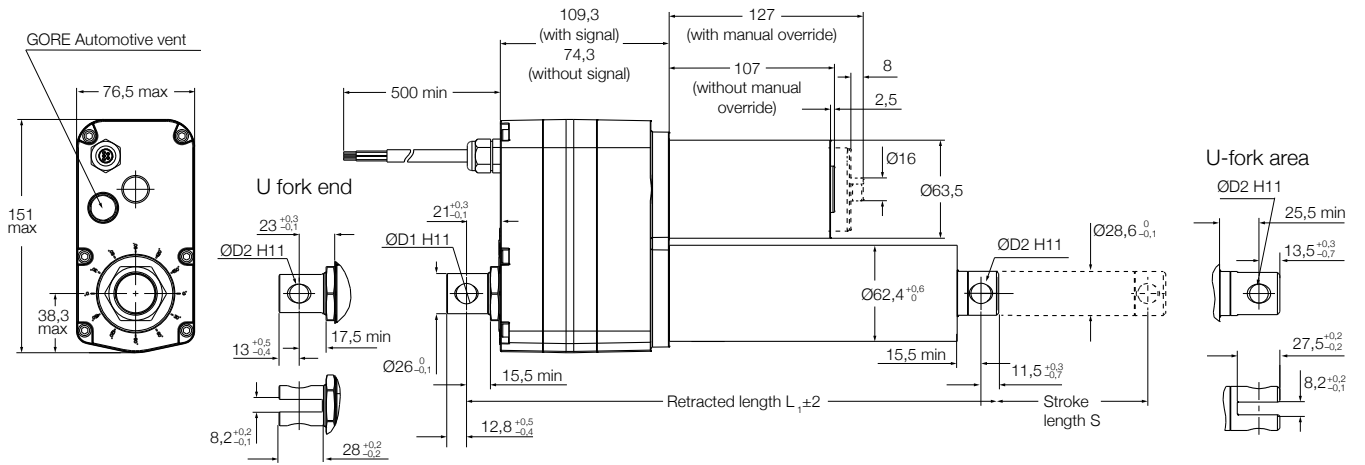

Rod end attachment (D1)

U fork attachment (D2)

Holes symbol	A	B	C	D	E	F	G
Hole dimension	13,1	12,8	12,5	14	12,2	12,2	12,8

	Rod end attachment	U fork attachment
S Stroke [mm]	50-305	306-700
L <sub>r</sub> retracted length no option	182 + stroke	217 + stroke
L <sub>r</sub> retracted length with LS	191 + stroke	226 + stroke
L <sub>r</sub> retracted length with signal	217 + stroke	252 + stroke
L <sub>r</sub> retracted length with LS and signal	226 + stroke	261 + stroke

Tolerance of stroke "S"  
 Without LS: if S ≤ 305 (±2); if S > 305 (±3)  
 With LS: if S ≤ 305 (-2, -0,5); if S > 305 (-3, -1)

### Manual override

Release the motor cover (1). Use the slot (2) to rotate the motor shaft (3) in the proper direction

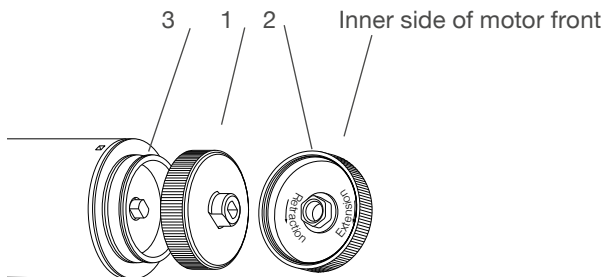

### Attachment

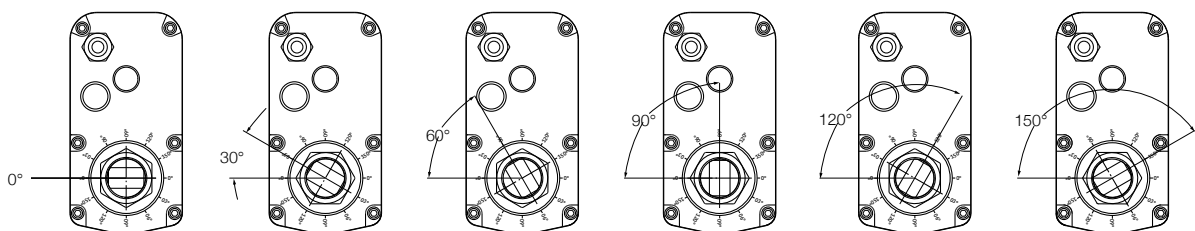

## Electrical specifications

### Wire connection with no signal

Wire no.	AWG	Colour	Application
1	14	Red	Motor power(+)=> Extension, (-)=> Retraction
2	14	Black	Motor power(-)=> Extension, (+)=> Retraction

### Wire connection with potentiometer

Wire no.	AWG	Colour	Application
1	22	Green	See picture description
2	22	White	See picture description
3	22	Brown	See picture description
4	14	Red	Motor power(+)=> Extension, (-)=> Retraction
5	14	Black	Motor power(-)=> Extension, (+)=> Retraction

### Potentiometer

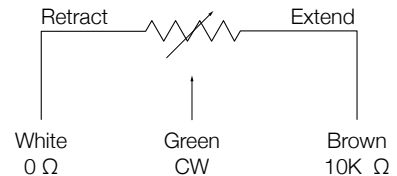

### Wire connection with encoder

Wire no.	AWG	Colour	Application
1	26	Green	Sensor signal 1 Encoder
2	26	Yellow	Sensor signal 2 Encoder
3	26	Black	Sensor power GND Encoder
4	26	Red	Sensor power 5 V Encoder
5	14	Red	Motor power(+)=> Extension, (-)=> Retraction
6	14	Black	Motor power(-)=> Extension, (+)=> Retraction

### Encoder

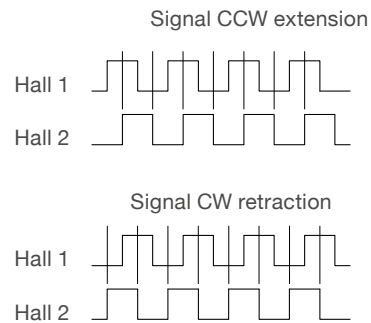

### Wire connection with absolute analog output

Wire no.	AWG	Colour	Application
1	22	Green	Output signal
2	22	White	Sensor power GND
3	22	Brown	Sensor power +10~55 VDC
4	14	Red	Motor power(+)=> Extension, (-)=> Retraction
5	14	Black	Motor power(-)=> Extension, (+)=> Retraction

### Absolut analog position output

Input voltage: 10~55 V DC  
 Current consumption: 15 mA max.  
 Output analog signal (voltage): 0~5 V DC  
 Max current output: 5 mA  
 Absolute analog output set up:  
 retraction 0,5±0,15 V  
 extension 4,5 to the maximum

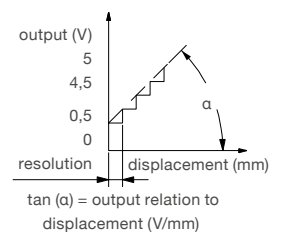

### Output relation to displacement and resolution

Actuator type	Hall sensor [pulses/mm]	Potentiometer [ohm/mm]	Absolute analogue position output [V/mm]	Resolution of the absolute analog position output [mm]
CAHB-21...E	1,56	33,33 if S=050-222	0,0167 if S=050-222	0,0732 if S=050-222
		16,67 if S=223-444	0,0083 if S=223-444	0,1465 if S=223-444
		5,56 if S=445-700	0,0028 if S=445-700	0,4395 if S=445-700

### Ordering key



**Type**

**Voltage**

- A 12 V DC
- B 24 V DC
- D 48 V DC
- E 12 V DC with manual override
- F 24 V DC with manual override
- H 48 V DC with manual override

**Load**

- 1 1 500 N
- 2 2 500 N
- 3 4 500 N

**Design**

E

**Stroke**

- 100 100 mm
- 150 150 mm
- 200 200 mm
- 250 250 mm
- 300 300 mm
- 350 350 mm
- 400 400 mm
- 450 450 mm
- 500 500 mm
- 600 600 mm
- 700 700 mm

**Retracted length<sup>1)</sup>**

Stroke	with limith switch	without position output	with position output
100 mm		291	326
150 mm		341	376
200 mm		391	426
250 mm		441	476
300 mm		491	526
350 mm		576	611
400 mm		626	661
450 mm		676	711
500 mm		726	761
600 mm		826	861
700 mm		926	961
	without limith switch		
100 mm		282	317
150 mm		332	367
200 mm		382	417
250 mm		432	467
300 mm		482	517
350 mm		567	602
400 mm		617	652
450 mm		667	702
500 mm		717	752
600 mm		817	852
700 mm		917	952

**Ingress protection**

B Standard: IP69K/IP66M

**Attachment diameter: (Front and rear)**

- A Hole Ø13,1 H11 (+0, +0,11 mm)
- B Hole Ø12,8 H11 (0, +0,11 mm)
- C Hole Ø12,5 H11 (+0, +0,11mm)
- D Hole Ø14 H11(+0,+0,11mm)
- E Hole 12.2 H11(+0,+0,11mm)
- F U fork hole 12,2 H11
- G U fork hole 12,8 H11
- X Customized

**Attachment orientation**

- A Standard (0°)
- B 30°
- C 60°
- D 90°
- E 120°
- F 150°
- X Customized

**Option 1: Limit switch**

- 0 None (mandatory for 1 500 N, 2 500 N version)
- L Limit switch (valid only for load version 4 500 N)

**Option 2: Position output**

- 0 None
- A Absolute analog output
- P Potentiometer
- E Encoder

**Thermal protection**

T Standard: Built-in thermal switch

**Customization**

Stroke length, retracted length, cable, connector, front attachment, rear attachment, color, de-rated load

<sup>1)</sup> Retracted length +12mm when attachments U fork are used.

In standard, the actuators are IP69K / IP66M and equipped with GORE Automotive vent, built-in thermal protection, protection Clutch and EMC filter.

# CAHB-22E

## Linear actuator

### Benefits

- High productivity
- Reliability and safety
- Save development time
- Cost effectiveness

### Features

- High force
- High speed
- High holding force
- Mechanical overload protection
- Enhanced ingress protection
- Corrosion protection and stainless steel tube
- Manual override option
- Virtuality maintenance free



### Technical data

Designation	Unit	CAHB-22E / 12 V				CAHB-22E / 24 V			
<b>Performance data</b>									
Rated Push Force	N	2 300	3 500	6 800	10 000	2 300	3 500	6 800	10 000
Rated Pull Force	N	2 300	3 500	6 800	10 000	2 300	3 500	6 800	10 000
Max pull / push Force <sup>1)</sup>	N	3 500	4 900	9 500	14 000	3 500	4 900	9 500	14 000
Holding force <sup>2)</sup>	N								
Speed without load <sup>3)</sup>	mm/s	55,0	45,0	22,0	13,0	53,0	45,0	22,0	13,0
Speed with the rated force <sup>3)</sup>	mm/s	42,0	36,0	15,5	10,2	42,0	37,0	17,0	10,2
<b>Electric data</b>									
Nominal voltage	V DC	12	12	12	12	24	24	24	24
Nominal current @ rated load <sup>3)</sup>	A	18	19,5	19,5	19	8	9,5	9,5	8,5
Rated current (clutch activation)	A	24,3	25,5	25,5	25	10,6	12,3	12,3	10,9
Duty cycle	%	10 (85/765 s)	10 (85/765 s)	10 (85/765 s)	10 (85/765 s)	20 (85/340 s)	20 (85/340 s)	20 (85/340 s)	20 (85/340 s)
<b>Mechanical data</b>									
Stroke	mm	50 ... 700	50 ... 700	50 ... 610	50 ... 450	50 ... 700	50 ... 700	50 ... 610	50 ... 450
Backlash	mm	1,0	1,0	0,6	0,6	1,0	1,0	0,6	0,6
Weight for 200 mm stroke	kg	4,8	4,8	4,8	4,8	4,8	4,8	4,8	4,8
Colour	-	Black	Black	Black	Black	Black	Black	Black	Black
<b>Environment and standards</b>									
Ambient temperature <sup>4)</sup>	°C	-40 ... 85	-40 ... 85	-40 ... 85	-40 ... 85	-40 ... 85	-40 ... 85	-40 ... 85	-40 ... 85
Degree of protection	-	IP 69K/66M							
Standards / EMC	-	EN61000-6-2:2005, EN61000-6-4:2007/A1:2011							
Salt spray test	-	ISO 9227:2012, 250 hours							

<sup>1)</sup> Upper limit of the pull/push force limited by the clutch. The lower limit is just above the rated force. The limitation of the force will happen between these 2 limits

<sup>2)</sup> Ultimate Static Load, refer to the "Static load" diagrams

<sup>3)</sup> The data of speed and current on this list is defined at +20 °C

<sup>4)</sup> Full performance from 0 °C to +40 °C

### Technical data

Designation	Unit	CAHB-22E / 48 V			
<b>Performance data</b>					
Rated Push Force	N	2 300	3 500	6 800	10 000
Rated Pull Force	N	2 300	3 500	6 800	10 000
Max pull / push Force <sup>1)</sup>	N	3 500	4 900	9 500	14 000
Holding force <sup>2)</sup>	N				
Speed without load <sup>3)</sup>	mm/s	57,0	45,0	22,0	13,0
Speed with the rated force <sup>3)</sup>	mm/s	50,0	37,0	18,5	10,2
<b>Electric data</b>					
Nominal voltage	V DC	48	48	48	48
Nominal current @ rated load <sup>3)</sup>	A	4,5	5	5	4,3
Rated current (clutch activation)	A	6,5	7	7	5,5
Duty cycle	%	20 (85/340 s)	20 (85/340 s)	20 (85/340 s)	20 (85/340 s)
<b>Mechanical data</b>					
Stroke	mm	50 ... 700	50 ... 700	50 ... 610	50 ... 450
Backlash	mm	1,0	1,0	0,6	0,6
Weight for 200 mm stroke	kg	4,8	4,8	4,8	4,8
Colour	-	Black	Black	Black	Black
<b>Environment and standards</b>					
Ambient temperature <sup>4)</sup>	°C	-40 ... 85	-40 ... 85	-40 ... 85	-40 ... 85
Degree of protection	-	IP 69K/66M			
Standards / EMC	-	EN61000-6-2:2005, EN61000-6-4:2007/A1:2011			
Salt spray test	-	ISO 9227:2012, 250 hours			

<sup>1)</sup> Upper limit of the pull/push force limited by the clutch. The lower limit is just above the rated force. The limitation of the force will happen between these 2 limits

<sup>2)</sup> Ultimate Static Load, refer to the "Static load" diagrams

<sup>3)</sup> The data of speed and current on this list is defined at +20 °C

<sup>4)</sup> Full performance from 0 °C to +40 °C

### Dimensional drawing

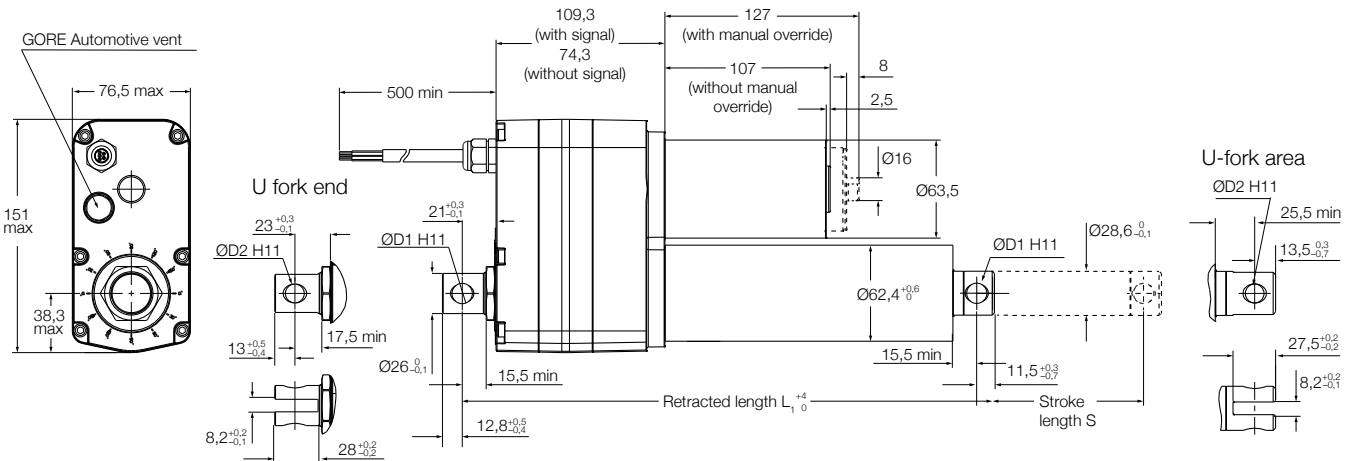

	Rod end attachment (D1)				U fork attachment (D2)		
Holes symbol	A	B	C	D	E	F	G
Hole dimension	13,1	12,8	12,5	14	12,2	12,2	12,8

	Rod end attachment	U fork attachment
S Stroke [mm]	50-305	306-700
L <sub>1</sub> retracted length no option	194 + stroke	229 + stroke
L <sub>1</sub> retracted length with LS	200 + stroke	235 + stroke
L <sub>1</sub> retracted length with signal	229 + stroke	264 + stroke
L <sub>1</sub> retracted length with LS and signal	235 + stroke	270 + stroke

Tolerance of stroke "S"

Without LS: for CAHB22-1E/2E if S ≤ 305 (-3, -1,5); if S > 305 (-4, -2) for CAHB22-3E/4E if S ≤ 305 (-2, -0,5); if S > 305 (-3, -1)

With LS: if S ≤ 305 (±2); if S > 305 (±3)

## Performance diagrams

Speed-load diagram

Speed [mm/s]

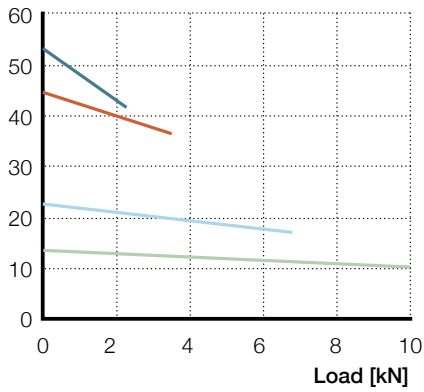

- Rated push force 2 300
- Rated push force 3 500
- Rated push force 6 800
- Rated push force 10 000

Current load diagram

Current consumption [A]

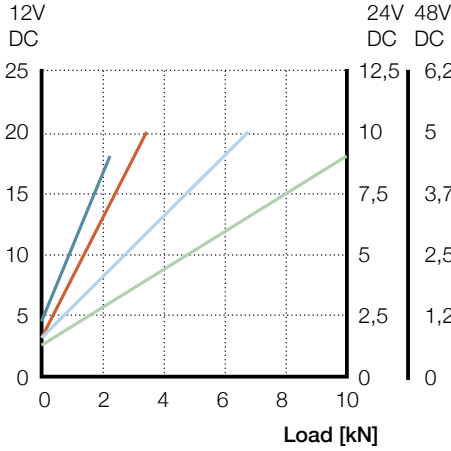

Static load diagram

Load [kN]

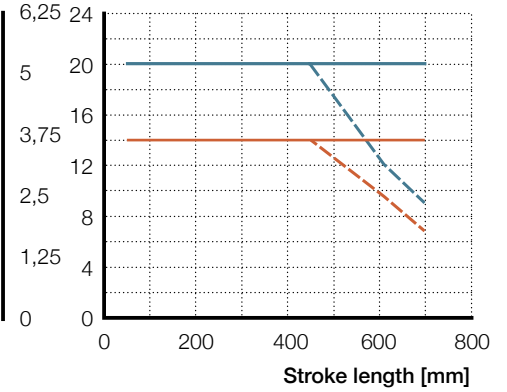

- Ultimate CAHB-22-xxE (pull)
- - - Ultimate CAHB-22-xxE (push)
- Recommended CAHB 22-xxE (pull)
- - - Recommended CAHB 22-xxE (push)

## Manual override

Release the motor cover (1). Use the slot (2) to rotate the motor shaft (3) in the proper direction

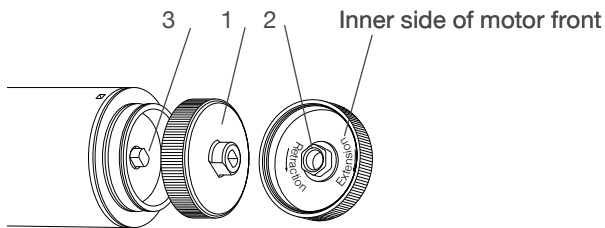

## Attachment

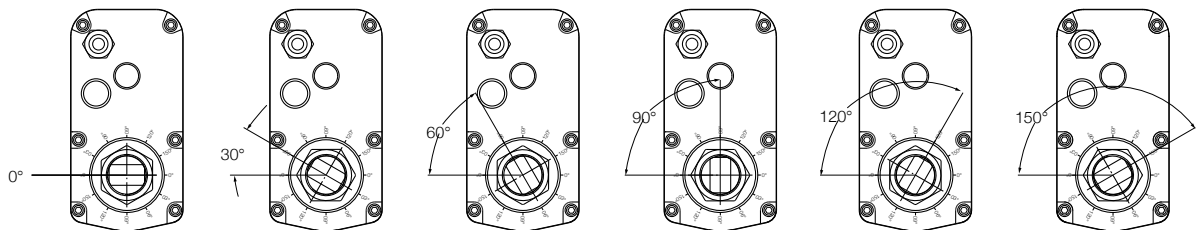



## Electrical specifications

### Wire connection with no signal

Wire no.	AWG	Colour	Application
1	14	Red	Motor power(+)=> Extension, (-)=> Retraction
2	14	Black	Motor power(-)=> Extension, (+)=> Retraction

### Wire connection with potentiometer

Wire no.	AWG	Colour	Application
1	22	Green	See picture description
2	22	White	See picture description
3	22	Brown	See picture description
4	14	Red	Motor power(+)=> Extension, (-)=> Retraction
5	14	Black	Motor power(-)=> Extension, (+)=> Retraction

### Wire connection with encoder

Wire no.	AWG	Colour	Application
1	26	Green	Sensor signal 1 Encoder
2	26	Yellow	Sensor signal 2 Encoder
3	26	Black	Sensor power GND Encoder
4	26	Red	Sensor power 5 V Encoder
5	14	Red	Motor power(+)=> Extension, (-)=> Retraction
6	14	Black	Motor power(-)=> Extension, (+)=> Retraction

### Wire connection with absolute analog output

Wire no.	AWG	Colour	Application
1	22	Green	Output signal
2	22	White	Sensor power GND
3	22	Brown	Sensor power +10~55 VDC
4	14	Red	Motor power(+)=> Extension, (-)=> Retraction
5	14	Black	Motor power(-)=> Extension, (+)=> Retraction

### Potentiometer

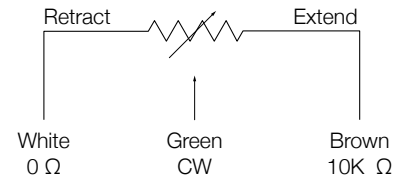

### Encoder

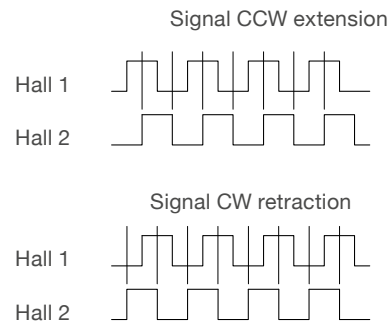

### Absolute analog position output

Input voltage: 10~55 V DC  
 Current consumption: 15 mA max.  
 Output analog signal (voltage): 0~5 V DC  
 Max current output: 5 mA

Absolute analog output set up:  
 retraction  $0,5 \pm 0,15$  V  
 extension 4,5 to the maximum

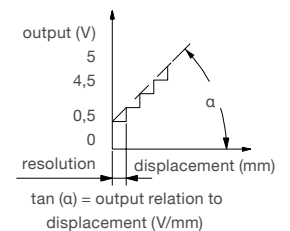

### Output relation to displacement and resolution

Actuator type	Hall sensor [pulses/mm]	Potentiometer [ohm/mm]	Absolute analogue position output [V/mm]	Resolution of the absolute analog position output [mm]
CAHB-22...1E	1,4	30 if S=050-254	0,0150 if S=050-254	0,0814 if S=050-254
CAHB-22...2E	1,4	15 if S=255-508 5 if S=509-700	0,0075 if S=255-508 0,0025 if S=509-700	0,1628 if S=255-508 0,4883 if S=509-700
CAHB-22...3E	2,8	60 if S=050-127	0,030 if S=050-127	0,0407 if S=050-127
CAHB-22...4E	2,8	30 if S=128-254 10 if S=255-700	0,015 if S=128-254 0,005 if S=255-700	0,0814 if S=128-254 0,2441 if S=255-700

Ordering key

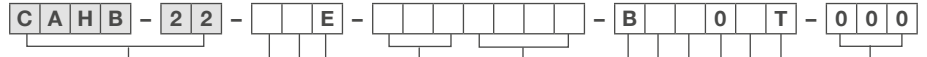

Type

Voltage

- A 12 V DC
- B 24 V DC
- D 48 V DC
- E 12 V DC with manual override
- F 24 V DC with manual override
- H 48 V DC with manual override

Load

- 1 2 300 N
- 2 3 500 N
- 3 6 800 N
- 4 10 000 N

Design

E

Stroke

- 100 100 mm
- 150 150 mm
- 200 200 mm
- 250 250 mm
- 300 300 mm
- 350 350 mm
- 400 400 mm
- 450 450 mm
- 500 500 mm
- 600 600 mm
- 700 700 mm

Retracted length<sup>1)</sup>

Stroke	with limith switch	without position output	with position output
100 mm		300	335
150 mm		350	385
200 mm		400	435
250 mm		450	485
300 mm		500	535
350 mm		585	620
400 mm		635	670
450 mm		685	720
500 mm		735	770
600 mm		835	870
700 mm		935	970
	without limith switch		
100 mm		294	329
150 mm		344	379
200 mm		394	429
250 mm		444	479
300 mm		494	529
350 mm		579	614
400 mm		629	664
450 mm		679	714
500 mm		729	764
600 mm		829	864
700 mm		929	964

Ingress protection

B Standard: IP69K/IP66M

Attachment diameter: (Front and rear)

- A Hole Ø13,1 H11 (+0, +0,11 mm)
- B Hole Ø12,8 H11 (0, +0,11 mm)
- C Hole Ø12,5 H11 (+0, +0,11 mm)
- D Hole Ø14 H11(+0, +0,11mm)
- E Hole Ø12,2 H11(+0,+0,11mm)
- F U fork hole 12,2 H11
- G U fork hole 12,8 H11
- X Customized

Attachment orientation

- A Standard (0°)
- B 30°
- C 60°
- D 90°
- E 120°
- F 150°
- X Customized

Option 1: Limit switch

- 0 None (mandatory for 2 300 N and 3 500 N version)
- L Limit switch (valid only for load version 6 800 N and 10 000 N)

Option 2: Position output

- 0 None
- A Absolute analog output
- P Potentiometer
- E Encoder

Thermal protection

T Standard: Built-in thermal switch

Customization

Stroke length, retracted length, cable, connector, front attachment, rear attachment, color, de-rated load

<sup>1)</sup> Retracted length +12mm when attachments U fork are used.

In standard, the actuators are IP69K / IP66M and equipped with GORE Automotive vent, built-in thermal protection, protection Clutch and EMC filter.

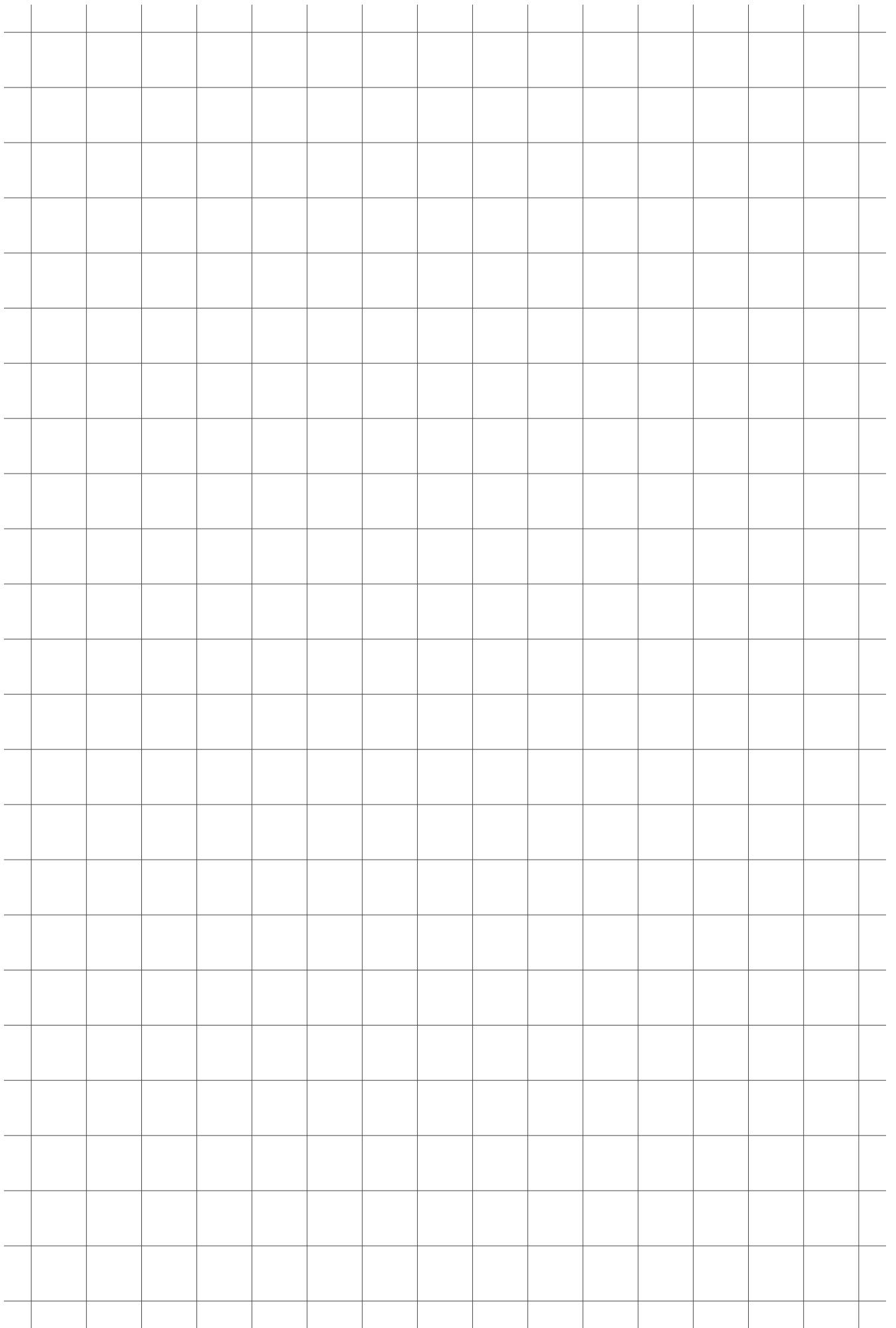

# CAHB-30A

## Linear actuator

### Benefits

- ACME screw drive
- Extension tube (stainless steel)
- Protection tube (steel)
- Enhanced corrosion resistance
- Mechanical overload protection (clutch)
- Maintenance free
- Robust, designed for tough environment
- Self-locking
- Motor with thermal protection



### Technical data

		Unit	CAHB-30A... 1	CAHB-30A... 2
Rated push load		N	1 500	2 300
Rated pull load		N	1 500	2 300
Speed (full load to no load)	115 V AC/60 Hz	mm/s	25 to 26	12 to 13
	230 V AC/50 Hz	mm/s	21 to 22	11 to 12
Stroke		mm	102 to 610	102 to 610
Retracted length		mm	– <sup>1)</sup>	– <sup>1)</sup>
Voltage		V AC	115 or 230	115 or 230
Power consumption		W	N/A	N/A
Current consumption	115 V AC/60 Hz	A	2,3	1,8
	230 V AC/50 Hz	A	1,35	1,4
Duty cycle		%	25 (94/376 s)	25 (94/376 s)
Ambient temperature		°C	–26 to +65	–26 to +65
Type of protection		IP	65S	65S
Weight		kg	9	9
Color		–	Black	Black

<sup>1)</sup> See dimensional drawing (L→ page 31)

For outdoors application, please contact Ewellix.

## Dimensional drawing

### Basic configuration (dashed line for optional limit switch)

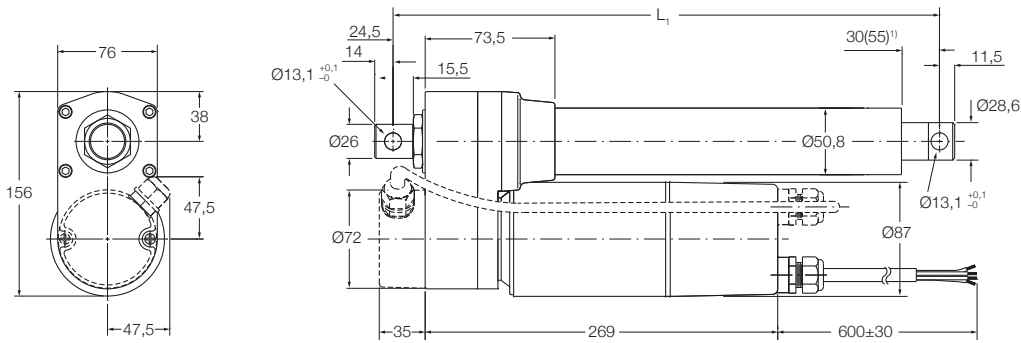

**Legend:**  
L<sub>1</sub> = retracted length

<sup>1)</sup> 55 = dimension with limit switch

### Optional potentiometer (dashed line for optional limit switch)

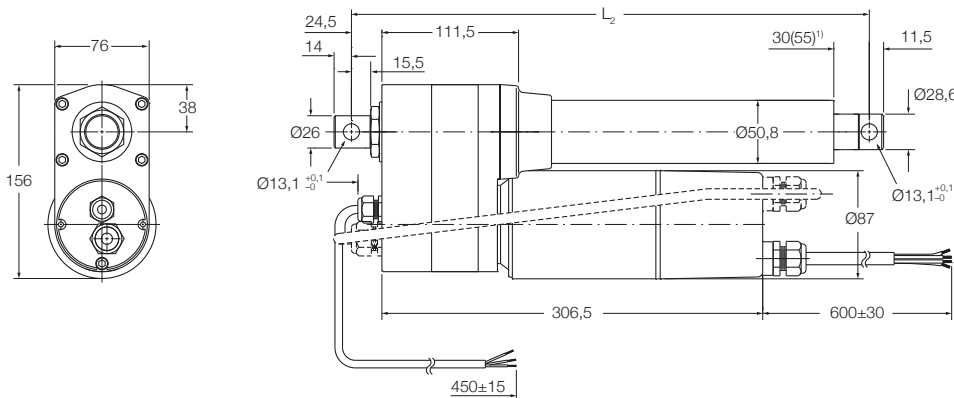

**Legend:**  
L<sub>2</sub> = retracted length

<sup>1)</sup> 55 = dimension with limit switch

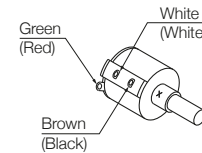
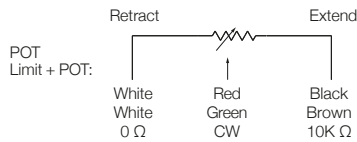
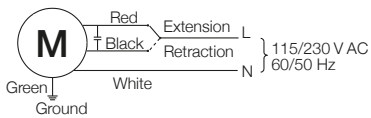

## Performance diagrams

### Speed-load diagram

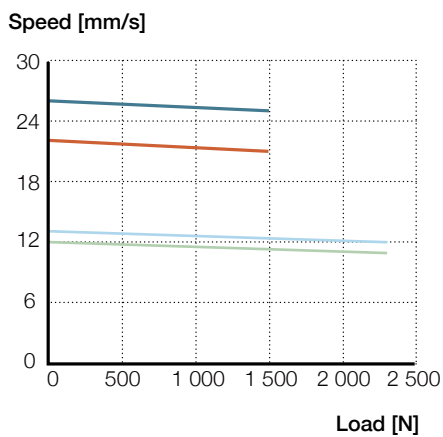

### Current-load diagram

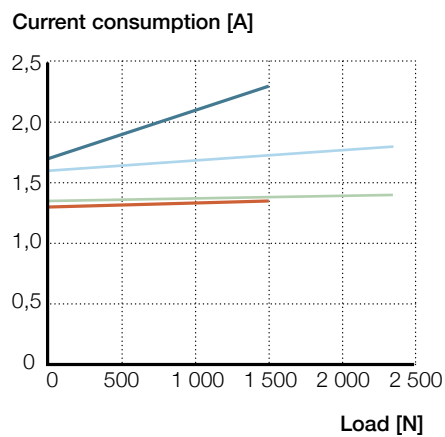

— 1 (115 VAC)

— 1 (230 VAC)

— 2 (115 VAC)

— 2 (230 VAC)

### Connecting diagram

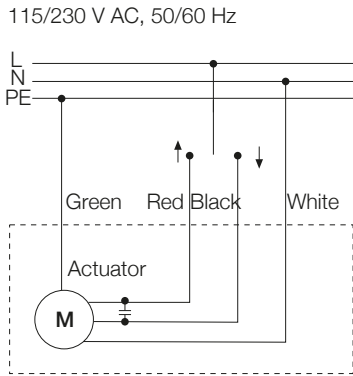

### Different rear attachment

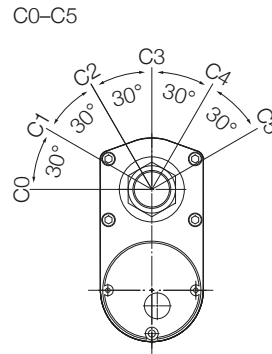

### Electrical specifications

#### Basic configuration

Stroke (mm)	With limit switch <sup>1)</sup>						Without limit switch <sup>2)</sup>					
	102	153	204	305	457	610	102	153	204	305	457	610
L1 Retracted length	440	440	440	592	744	897	380	415	415	465	668	821

<sup>1)</sup> Tolerance: S and L1 = ± 5,0 mm (If S ≥ 305 mm, S = ± 7,5 mm)

<sup>2)</sup> Tolerance: S = ± 2,5 mm and L1 = ± 3,8 mm

#### Optional potentiometer

Stroke (mm)	With limit switch <sup>1)</sup>						Without limit switch <sup>2)</sup>					
	102	153	204	305	457	610	102	153	204	305	457	610
L2 Retracted length	478	478	478	630	782	935	418	453	453	503	706	859

<sup>1)</sup> Tolerance: S and L2 = ± 5,0 mm (If S ≥ 305 mm, S = ± 7,5 mm)

<sup>2)</sup> Tolerance: S = ± 2,5 mm and L2 = ± 3,8 mm

#### Potentiometer resolution

Stroke (mm)	102	153	204	305	457	610
Ohm/mm	59,0	59,0	29,5	29,5	9,84	9,84

## Ordering key

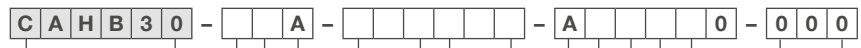

**Type**

**Voltage**

- N 115 V AC
- P 230 V AC

**Load**

- 1 1 500 N
- 2 2 300 N

**Screw**

- A Acme screw

**Stroke**

- 102 102 mm
- 153 153 mm
- 204 204 mm
- 305 305 mm
- 457 457 mm
- 610 610 mm

**Retracted length**

Stroke	with limith switch1)	without POT2)	with POT2)
102 mm		440	478
153 mm		440	478
204 mm		440	478
305 mm		592	630
457 mm		744	782
610 mm		897	935
	without limith switch1)		
102 mm		380	418
153 mm		415	453
204 mm		415	453
305 mm		465	503
457 mm		668	706
610 mm		821	859

**IP**

- A Standard (IP 65)

**Front attachment**

- A Standard (hole: Ø13,1 mm)
- X Customized

**Rear attachment**

- A Standard (0° and hole: Ø13,1 mm)
- B 30°
- C 60°
- D 90°
- E 120°
- F 150°
- X Customized

**Option 1**

- 0 None
- L Limit switch (only for load version 2 300 N)

**Option 2**

- 0 None
- P Potentiometer

**Customization**

Options shown in red are only available on request. Contact Ewellix for more information on minimum quantities and additional costs.



# CAHB-31N

## Linear actuator

### Benefits

- High efficiency ball screw
- Extension tube (stainless steel)
- Protection tube (steel)
- Enhanced corrosion resistance
- Mechanical overload protection (clutch)
- Lubricated for service life
- Robust, designed for tough environment
- No back driving
- Motor with thermal protection



### Technical data

		Unit	CAHB-31N... 1	CAHB-31N... 2	CAHB-31N... 3
Rated push load		N	2 300	4 500	6 000
Rated pull load		N	2 300	4 500	6 000
Speed (full load to no load)	115 V AC/60 Hz	mm/s	48 to 57	22 to 28	13 to 15
	230 V AC/50 Hz	mm/s	40 to 50	20 to 24	11 to 13
Stroke		mm	102 to 610	102 to 610	102 to 610
Retracted length		mm	– <sup>1)</sup>	– <sup>1)</sup>	– <sup>1)</sup>
Voltage		V AC	115 or 230	115 or 230	115 or 230
Power consumption		W	N/A	N/A	N/A
Current consumption	115 V AC/60 Hz	A	3	2,6	2,2
	230 V AC/50 Hz	A	1,5	1,4	1,4
Duty cycle		%	25 (94/376 s)	25 (94/376 s)	25 (94/376 s)
Ambient temperature		°C	–26 to +65	–26 to +65	–26 to +65
Type of protection		IP	65S	65S	65S
Weight		kg	9,5	9,5	9,5
Color		–	Black	Black	Black

<sup>1)</sup> See dimensional drawing (↳ page 35)

For outdoors application, please contact Ewellix.



## Dimensional drawing

### Basic configuration (dashed line for optional limit switch)

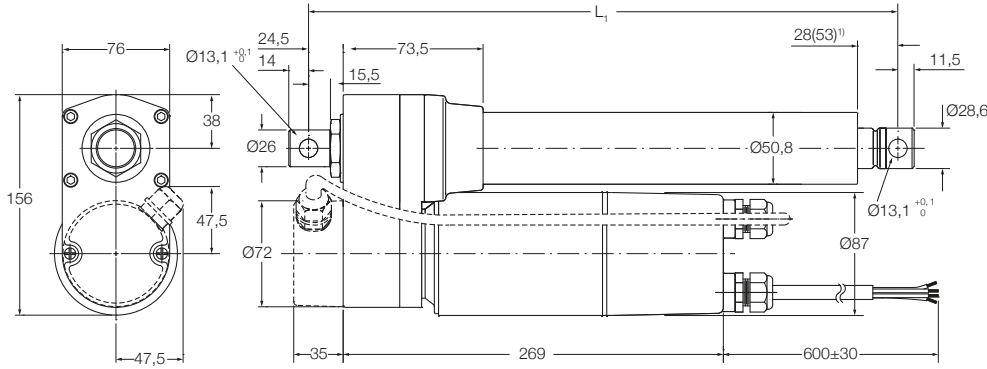

**Legend:**  
L<sub>1</sub> = retracted length

<sup>1)</sup> 53 = dimension with limit switch

### Optional potentiometer (dashed line for optional limit switch)

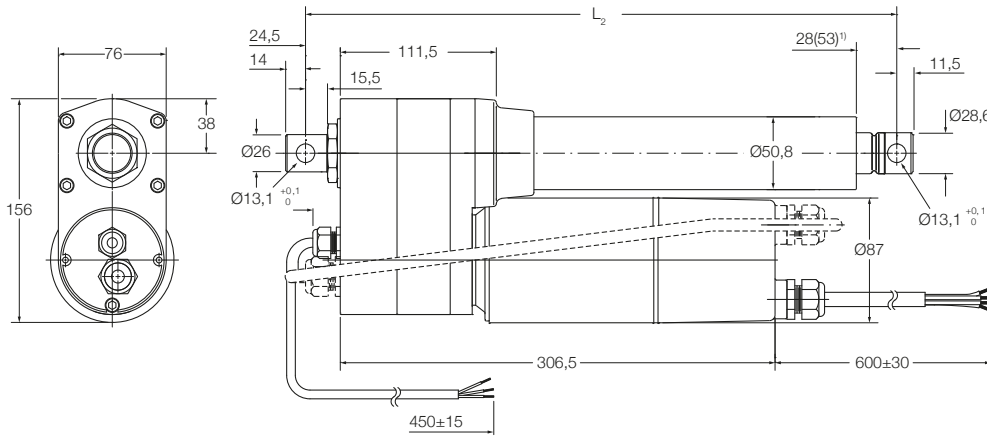

**Legend:**  
L<sub>2</sub> = retracted length

<sup>1)</sup> 53 = dimension with limit switch

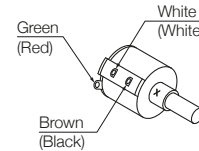
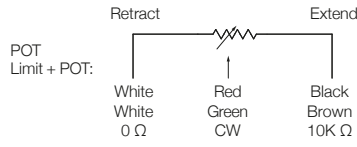
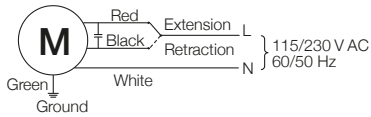

## Performance diagrams

### Speed-load diagram

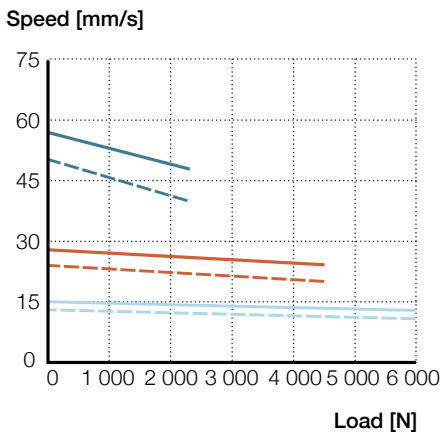

### Current-load diagram

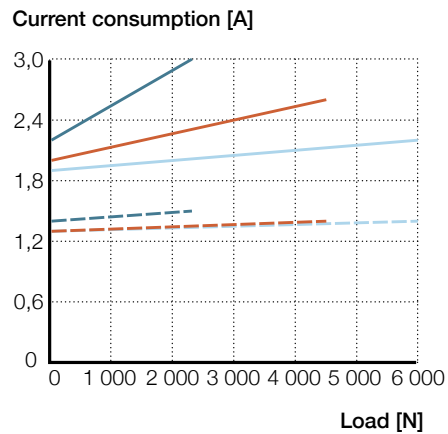

- 1 (115 VAC)
- 2 (115 VAC)
- 1 (230 VAC)
- 2 (230 VAC)
- 3 (115 VAC)
- 3 (230 VAC)

### Connecting diagram

115/230 V AC, 50/60 Hz

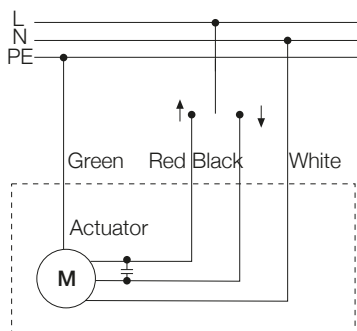

### Different rear attachment

C0-C5

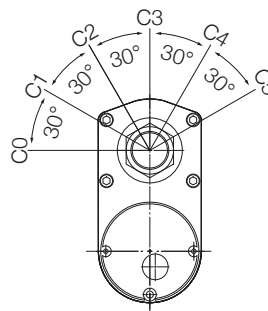

### Electrical specifications

	With limit switch <sup>1)</sup>						Without limit switch <sup>2)</sup>					
	102	153	204	305	457	610	102	153	204	305	457	610
Stroke (mm)												
L1 Retracted length	444	444	495	659	811	964	380	419	419	521	735	888

<sup>1)</sup> Tolerance: S and L1 = ± 5,0 mm (If S ≥ 305 mm, S = ± 7,5 mm)

<sup>2)</sup> Tolerance: S = ± 2,5 mm and L1 = ± 3,8 mm

	With limit switch <sup>1)</sup>						Without limit switch <sup>2)</sup>					
	102	153	204	305	457	610	102	153	204	305	457	610
Stroke (mm)												
L2 Retracted length	482	482	533	697	849	1002	418	457	457	559	773	926

<sup>1)</sup> Tolerance: S and L2 = ± 5,0 mm (If S ≥ 305 mm, S = ± 7,5 mm)

<sup>2)</sup> Tolerance: S = ± 2,5 mm and L2 = ± 3,8 mm

Potentiometer resolution	
Stroke (mm)	102                      153                      204                      305                      457                      610
Ohm/mm	59,0                      59,0                      29,5                      29,5                      9,84                      9,84

## Ordering key

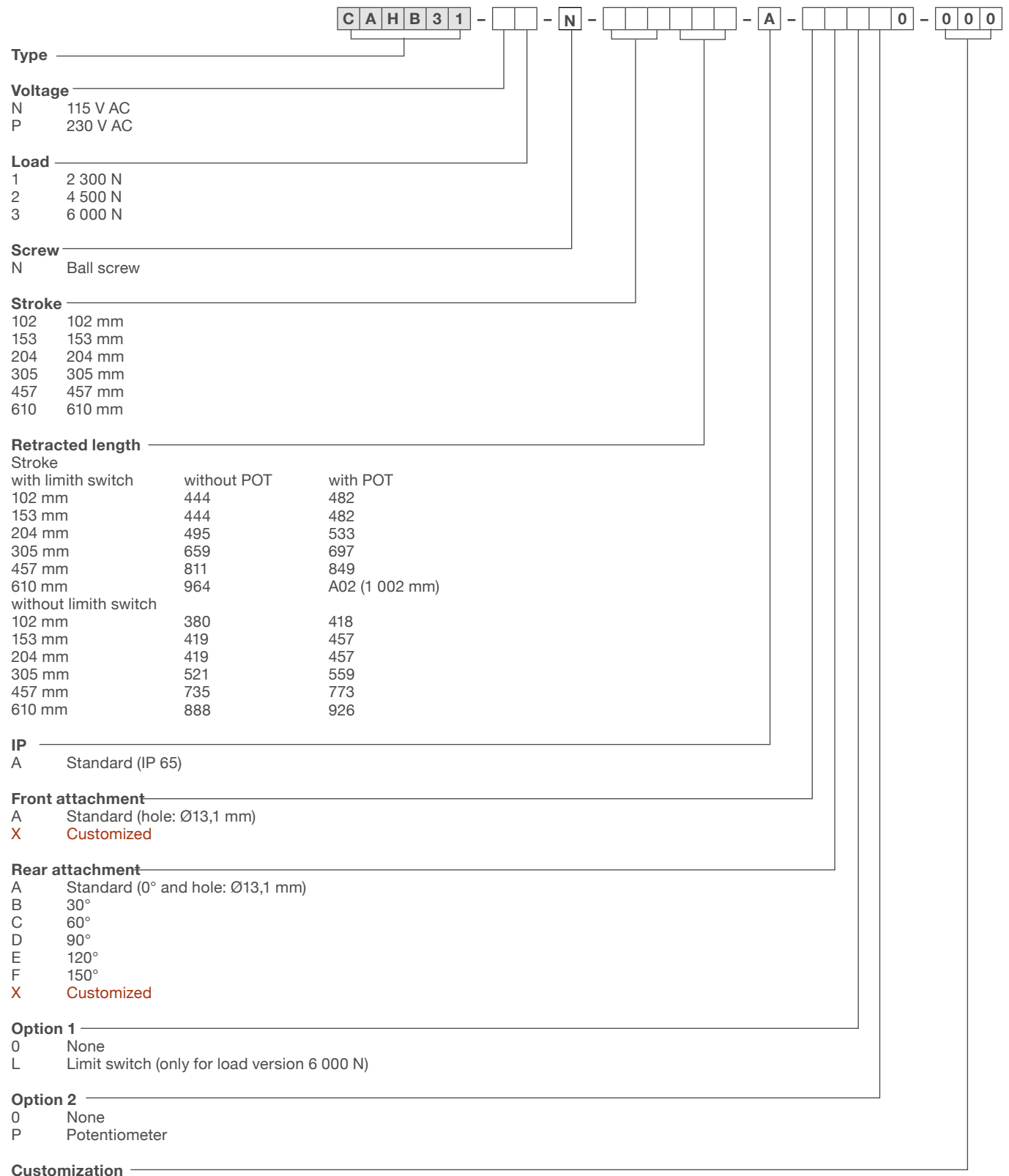

Options shown in red are only available on request. Contact Ewellix for more information on minimum quantities and additional costs.

CAHB series - Environmental tests

Climatic tests						
Test and Standard	CAHB-20xE, CAHB-21xE, CAHB-22xE Performance	Report No.	CAHB-10 Performance	Report No.	CAHB-30, CAHB-31 Performance	Report No.
<b>Cold test EN60068-2-1 (Ab)</b>	Storage at low temperature Temperature: -40 °C Duration: 6 hours Not connected Tested at room temperature.	PH_TR0295	Storage at low temperature Temperature: -40 °C Duration: 96 hours Not connected Tested at room temperature.	"Low temperature for CAHB-10"	Storage at low temperature: Temperature: -40 °C Duration: 8 hours Not connected Tested at room temperature.	PH_TR0265
<b>Cold test EN60068-2-1 (Ad)</b>	Storage at low temperature Temperature: -30 °C Duration: 6 hours Actuator is not activated/ connected Tested at low temperature.	PH_TR0295	Storage at low temperature Temperature: -20 °C Duration: 96 hours Actuator is not activated/ connected Tested at low temperature.	"Low temperature for CAHB-10"	Storage at low temperature: Temperature: -26 °C Duration: 8 hours Not connected  Tested at room temperature.	PH_TR0265
<b>Dry Heat EN60068-2-2 (Bb)</b>	Storage at high temperature Temperature: +90 °C Duration: 72 hours Actuator is not activated/ connected. Tested at room temperature	PH_TR0278	Storage at high temperature Temperature: +85 °C Duration: 96 hours Actuator is not activated/ connected. Tested at room temperature	"High temperature for CAHB-10"	-	-
<b>Change of temperature EN60068-2-14 (Na)</b>	Rapid change of temperature High temperature: +100 °C in 60 min. Low temperature: -30 in 60 min. Transition time: < 10 seconds Duration: 100 cycles Actuator is not activated/ connected. Tested at room temperature.	PH_TR0278	-	-	-	-
<b>Salt mist EN60068-2-52 (Kb)</b>	Salt spray test Salt solution: 5 % sodium chloride (NaCl) 4 spraying periods, each of 2 hours. Humidity storage 7 days after each. Actuator not activated/ connected. Exposure time: 250 hours	PH_TR0268	Salt spray test Salt solution: 5 % sodium chloride (NaCl) 4 spraying periods, each of 2 hours. Humidity storage 7 days after each. Actuator not activated/ connected. Exposure time: 96 hours	"Salt spray test for CAHB-10"	-	-
<b>Degrees of protection IEC 60529</b>	1. Test Item: IP6XM Test Condition: Movement Test Dust: Talcum powder  Dust Concentration: 2 kg/m <sup>3</sup> chamber volume and be kept in suspension during the test Test Duration: 8 hours	SHIN1607036235PS	1. Test Item: IP6XS Test Condition: Static Type of dust: Talcum powder  Test Duration: 8 hours	COM12-GPE080184AN, COM12-GPE080183AN	-	-
<b>Degrees of protection IEC 60529</b>	2. Test Item: IPX6M Test Condition: Movement Flux: 100 L/min Nozzle diameter: Ø12,5 mm  Distance: 2,5 ~ 3,0 m Test duration: 3 min	SHIN1607036235PS	2. Test Item: IPX6S Test Condition: Static Flux: 100 (1 ±5 %) L/min Nozzle diameter: Ø12,5 mm Distance: 2,5 ~ 3,0 m Test duration: 3 min	COM12-GPE080184AN, COM12-GPE080183AN	2. Test Item: IPX5S Test Condition: Static Flux: 12,5 L/min Nozzle diameter: Ø6,3 mm Distance: 2,5 ~ 3,0 m Test duration: 3 min	SHIN1608042057MR
<b>Degrees of protection ISO 20653:2013</b>	3. Test Item: IPX9K Test Condition: Static Jet angle: 2507 Water flow: 14~16 L/min Water pressure: 8 000~10 000 kPa Water temperature: 80 to -5 °C Test angle: 0°, 30°, 60°, 90°  Test distance from jet to sample: 100~150 mm Test duration: 30 s/position	SHIN1607036235PS	3. Test Item: IPX9K Test Condition: Static Jet angle: 2507 Water flow: 14~16 L/min Water pressure: 8 000~10 000 kPa Water temperature: 80 to -5 °C Test angle: 0°, 30°, 60°, 90° Test distance from jet to sample: 100~150 mm Test duration: 30 s/position	SHIN1510048959MR-01	-	-

## Mechanical tests

Test and Standards	CAHB-20xE, CAHB-21xE, CAHB-22xE		CAHB-10		CAHB-30, CAHB-31	
	Performance	Report No.	Performance	Report No.	Performance	Report No.
<b>Vibration</b> <b>EN60068-2-6 (Fdb)</b> <b>EN60068-w2-6(Fc)</b>	Test Item: Random vibration Frequency (Hz) Power spectral density level 10 200 300 350 Test Direction: X/Y/Z axis Test Duration: 2 hours/axis, Total 6 hours Test Item: Sinusoidal vibration Test Condition: Frequency range: 5~25~200 Hz Amplitude: 3,3 mm (p-p) Acceleration: 4g Sweep Rate: 10 ct/min Test Direction: X/Y/Z axis Test Duration: 2 hours/axis, Total 6 hours	SHIN1607036235PS SHIN1702007025PS	-	-	-	-
<b>Vibration</b> <b>Ewellix Specified</b> <b>Conditions</b>	-	-	Test Item: Vibration Set Point (Grms) 5 10 15 20 20 20 Test Equipment Name Halt Tester	Dwell Time(min) 10 10 10 10 20 30 Typhoon-2,5+	SHIN1805034119SC SHIN1805032588SC	-

## Electrical tests

Test and Standards	CAHB-20xE, CAHB-21xE, CAHB-22xE		CAHB-10		CAHB-30, CAHB-31	
	Performance	Report No.	Performance	Report No.	Performance	Report No.
<b>Power supply 12 VDC</b> <b>ASAE EP455 (1990)</b>	Operating voltages: +10 V ~ +16 V Over voltage: +26 V / 5 min. Reverse polarity: -26 V / 5 min. Short circuit to ground: 16 V / 5 min. Short circuit to supply: 16 V	PH_TR0267 PH_TR0302	-	-	-	-
<b>Power supply 24 VDC</b> <b>ASAE EP455 (1990)</b>	Operating voltages: +21 V ~ +26 V Over voltage: +36 V / 5 min Reverse polarity: -36 V / 5 min Short circuit to ground: 32 V / 5 min Short circuit to supply: 32 V	PH_TR0267 PH_TR0302	-	-	-	-
<b>Safety Low Voltage Directive</b> <b>EN 60335-1: 2012 + A11: 2014</b>	-	-	-	-	Rated Voltage: 230 V AC Rated frequency: 50 Hz Rated Current: 1,5 A Degree of protection: IP65	UL 4787638796
<b>EN 60335-2-97 : 2006 + A11: 2008 + A2:2010 + A12: 2015</b> <b>EN 62233 : 2008</b>	-	-	-	-	Rated Voltage: 230 V AC Rated frequency: 50 Hz Rated Current: 1,5 A Degree of protection: IP65	UL 4787638796
<b>EMC, HF-immunity</b> <b>EN 61000-6-1</b>	-	-	Pass the test for 12 V / 24 V Motor	70.888.12.1063.02	-	-
<b>EN 61000-6-2</b>	Pass the test for 12 V / 24 V Motor	708881688102-00	-	-	-	-
<b>EMC, Emission</b> <b>EN 61000-6-3</b>	-	-	Inside limits for 12 V / 24 V motor	70.888.12.1063.02	-	-
<b>EN 61000-6-4</b>	Inside limits for 12 V / 24 V motor	708881688102-00	-	-	-	-
<b>EN 50081-2 (1993)</b> <b>EN 55011 (1998)</b>	-	-	-	-	Class B	EM99777 (IA4=CAHB-30 CAHB-31 series)
<b>EMC, Automotive transients</b> <b>ISO 7637-2</b>	ISO 7637 Load dump test only accepted on motor power connection	708881688103-00	-	-	-	-
<b>UL certification</b>	-	-	-	-	UL 325 ANSI/CAN/UL-Door	20190822-E507157



## ewellix.com

© Ewellix

All contents of this publication are the property of Ewellix, and may not be reproduced or given to third parties (even extracts) without permission. Although great care has been taken in the production of this catalog, Ewellix does not take any responsibility for damage or other loss resulting from omissions or typographical errors. The photo may differ slightly in appearance from the actual product. Due to continuous improvements being made in our products, the product's appearance and specifications are subject to change without notice.

**PUB IL-06006-EN-October 2019**

Certain image(s) used under license from Shutterstock.com.  
SKF and SKF logo are trademarks of the SKF Group